

KENOVA set line V5 new generation



EN Operating Instructions KENOVA set line V5 new generation

Operating Instructions version 1.0

Document No. / Article No.: 1067628

© KELCH GmbH 2015

All rights reserved. Subject to technical changes

14.12.2015

Table of Contents

Table of Contents	I
List of Figures	III
List of Tables	IV
1 Product Liability and Warranty	1
1.1 General	1
1.2 Warranty	2
1.3 Servicing	2
1.4 Intended Use	4
1.5 Disposal of the Unit	5
2 Safety	6
2.1 Warnings and Hazard Symbols	6
2.2 Fundamental Safety Rules	8
2.3 Spare Parts and Accessories	8
2.4 Requirements Governing Operating and Maintenance Personnel	8
2.5 Safety Measures	10
2.6 Safety Stickers on the Unit	11
2.7 Hazard Points on the Unit and During Operation	12
2.8 Dangers from Electrical Power / Voltage	13
2.9 Pneumatic Supply	13
2.9.1 Dangers from Hydraulic and Pneumatic Energy	14
2.9.2 Danger from Lubricants	15
2.10 Opening the Housing	15
3 Commissioning	16
3.1 Transport / Packaging / Storage	16
3.2 Scope of Delivery	20
3.2.1 Components of the KENOVA set line V5 new generation	21
3.3 Commissioning and Removal of the Transport Fixings	22
3.4 Installation	24
3.5 Mains Connection	24
3.6 Pneumatic Connection	26
3.7 PC Connection and Peripherals	26
3.8 Handover	27
4 Switching On and Getting Started	28
4.1 Referencing the Axes (Homing)	29
4.2 Calibration Process	31
4.3 Properties and Use of the Control Panel	33
4.3.1 Use of the Automatic Tool Clamp (4)	33
4.3.2 Using the Spindle Brake (3)	33
4.3.3 Using the Spindle Brake with Indexing (2)	34
4.3.4 Use of the Top Light	35
4.4 Inserting a Tool into the Spindle	36

4.5	Tool Presetting and Measurement.....	37
4.6	Switching Off the System.....	39
4.7	Instructions for Using the Machine	39
5	Maintenance and Care	40
5.1	Safety Measures.....	40
5.2	Inspection	41
5.3	Cleaning	41
5.4	Maintenance	41
5.4.1	Maintenance Schedule.....	43
6	Technical Data.....	44
6.1	Measuring Ranges and Unit Dimensions.....	44
6.2	Connection and Consumption Figures.....	45

List of Figures

Figure 1 Example of a nameplate	3
Figure 2: KENOVA set line V5 new generation with tool mounting plate (optional)	4
Figure 3 Example of the packaging	16
Figure 4 Unit fixed on the pallet	17
Figure 5 Positions of the transport fixings	18
Figure 6 Fixing the transport straps	18
Figure 7 Components of the KENOVA set line V5 new generation	21
Figure 8 Positions of the transport fixings	22
Figure 9 Visualisation of the electrical and pneumatic connections	25
Figure 10 Assignment of ports on the PC	27
Figure 11 Mains switch	28
Figure 12 Information for axis referencing	29
Figure 13 Camera light holder with handle	30
Figure 14 Plate with zero point coordinates	31
Figure 15 Visualisation of the reference notch	31
Figure 16 Reference notch not in focus	31
Figure 17 Focussing procedure	32
Figure 18 Control panel	33
Figure 19 Camera and light holder	35
Figure 20 Output control of the top light	35
Figure 21 Inserting the tool and clamping with the adapter lock	37
Figure 22 Operating the spindle brake	38

List of Tables

Table 1: Dangerous points on the unit.....	12
Table 2: Measuring ranges of KENOVA set line V5 new generation	44
Table 3: Connection and consumption values of the KENOVA set line V5 new generation	45

1 Product Liability and Warranty

1.1 General

These operating instructions are essential to ensure the safe, correct and efficient operation of the unit. Complying with these operating instructions will help to avoid hazards, reduce repair costs and down times and increase the reliability and service life of the entire machine.

It is imperative that anyone who works with and on the unit reads and implements the operating instructions, and in particular the “Safety” chapter.

Operation

including setting up, fault rectification during operation, disposal of production waste, care, disposal of operating materials and consumables

Servicing

Maintenance, inspection, repairs

Transport

Apart from the operating instructions and the accident prevention regulations applicable in the country of use and place of use, it is mandatory that all recognised technical regulations for safety and correct operation are adhered to, as well as all workshop-specific regulations.

Please contact **KELCH GmbH** in the event of doubt:

KELCH GmbH

Werkstrasse 30

D-71384 Weinstadt-Endersbach, Germany

Phone:	(+49) 7151 20522	0	Switchboard
		500	Service
Fax:		11	
E-mail:	info@kelchgmbh.de		
Internet:	www.kelch.de		

1.2 Warranty

It is anticipated that the unit retains its performance, operational safety and operating precision for many years to come. This can only be ensured by complying with the operating, maintenance and servicing regulations.

During the warranty period, any faults that occur will be rectified by **KELCH GmbH** in accordance with the warranty conditions. All consequences of unauthorised conversions and modifications will be borne by the operator. This applies in particular to modifications that impair the safety of the unit.

Warranty only covers the use of **genuine original spare parts**.

Contravening this will result in **KELCH GmbH** declining all liability.

On receipt, immediately check the completeness of the delivery against the order confirmation / delivery note.

These operating instructions do not extend the **KELCH GmbH** Terms and Conditions of Sale and Delivery!

1.3 Servicing

We strongly recommend that you keep a stock of the most important spare parts and wear parts at the place of use to maintain the operational readiness of the unit. Please ask us for a non-binding quotation.

KELCH GmbH is available for extensive repair and overhaul work on the unit. Please state the following with all written or telephone enquiries or orders:

Assembly in question

Serial number and **year of manufacture** of the unit:

This information can be found on the nameplate.

1. Product Liability and Warranty

An example of a nameplate is shown below:

- 1 - KELCH logo with address
- 2 - Type name
- 3 - Article number
- 4 - Serial number
- 5 - Year of manufacture
- 6 - CE mark



Figure 1 Example of a nameplate

1.4 Intended Use



Figure 2: KENOVA set line V5 new generation with tool mounting plate (optional)

The KENOVA set line V5 new generation tool presetter is used to measure tools. In the following document, “tool” is understood as meaning the complete tool, i.e. a tool in its tool holder.

Make sure that the temperature of the tool is at around room temperature.

Any other use or any use for any other purpose is deemed to be improper use. **KELCH GmbH** accepts no liability for damage resulting from this. The operator alone shall bear this risk.

Intended use also includes compliance with the operating instructions, as well as adherence to the inspection and maintenance intervals prescribed by **KELCH GmbH**.

1.5 Disposal of the Unit

No composite materials were used – where possible – in the design of the unit. This design concept ensures a high level of recycling once the unit has reaching the end of its service life. We are therefore also prepared to take back the unit for correct disposal at a fee. We would also draw your attention to the fact that compliance with the provision of the Electronic Scrap Ordinance should be ensured.

2 Safety

2.1 Warnings and Hazard Symbols

The following designations and symbols are used in these operating instructions to indicate important information:

**Warning!****Danger of death or serious physical injury!**

Non-observance poses the risk of possible or direct serious physical injury or death.

**Caution!****Risk of slight physical injury or damage to property!**

Non-observance poses the slight risk of physical injury or damage to property!

**Warning!****Warning of non-ionising electromagnetic radiation!**

Do not expose equipment sensitive to interference and people with active and, in certain cases, also passive medical implants to the unit's electromagnetic field.

**Warning!****Warning of hazardous electrical voltage!**

Never use this unit if it is damaged: loose cable connections, defective insulation, burnt cables and other damage that impairs the electrical safety of the appliance.

**Warning!****Warning of toxic substances!**

Residual cooling lubricants, oils or greases can vaporise during shrinking. Do not inhale oil vapours! Oil vapours are harmful to health and can contain carcinogenic substances.

**Warning!****Warning of hot surfaces!**

Do not reach into the induction coil or move objects close to the coil during shrinking. Risk of injury due to burns from hot parts!



Warning!

Warning of explosive and combustible substances!

Never operate the shrink fit device (if fitted) in environments at risk of fire or explosion or in the vicinity of combustible, flammable or explosive substances.



Warning!

Warning of being caught on rotating equipment!

Make sure that you do not wear loose objects, such as jewellery, when operating the machine. The same applies to the rotational axis of the presetter.



Prohibited! Prohibited for persons with medical implants!

Do not allow personnel with active medical implants to work on this unit and, for safety reasons, ensure that they remain at a distance of 3 metres from the unit.



Important note!

Specific information to remember or information we have gained from our experience. For example a useful hint or idea for carrying out an action extremely efficiently.

2.2 Fundamental Safety Rules

The unit is designed in line with the state of the art and applicable safety regulations.

Nevertheless, the unit can pose special hazards if insufficiently trained personnel are allowed to carry out the installation or if the unit is incorrectly used or is not used as intended.

Note the following accident prevention regulations:

- The company's accident prevention regulations
- General accident prevention regulations
- VDE safety regulations

2.3 Spare Parts and Accessories

Only use accessories and spare parts authorised by **KELCH GmbH**.

These parts have been checked and approved by **KELCH GmbH**. Otherwise the active and passive safety of the unit can be impaired!

KELCH GmbH does not accept liability and warranty claims for damage caused by the non-use of original parts and accessories.

2.4 Requirements Governing Operating and Maintenance Personnel

Before working on the unit, make sure that anyone involved with the setting up, installation, commissioning, operation and servicing of the unit has read and understood these operating instructions, in particular the “**Safety**” “**Commissioning**” and “**Operation and Language Set-up**” chapters. This applies in particular to people who only occasionally work on the appliance.

The operator has a responsibility to instruct the operating and servicing personnel in the operation and servicing of the unit, taking into consideration all safety regulations.

Only deploy persons who have had appropriate training for this type of work to operate and maintain the unit. This applies particularly to work on the unit's electrical, pneumatic and mechanical equipment.

Persons being trained, instructed or personnel undergoing general training are permitted to carry out work on the unit but only under constant supervision of an experienced person!

2. Safety

If more than one person is working on the unit, then responsibilities for the individual tasks must be clearly defined and adhered to. From a safety aspect, make sure that there are no unclear spheres of responsibility!



Important note! Inform operating personnel before commencing special work and repairs. Nominate a supervisor!

2.5 Safety Measures

Adhere to the **company's regulations** to avoid accidents!

Operating personnel have a **responsibility** to take the following safety measures when working with the unit:



Hands

Wear hand protection!

Possible sharp edges or swarf adhering to the tool can cause cuts. Personnel can also be burned from the heated shrink chuck (if fitted).

Risk of injury due to crushing when inserting the tool.

Always wear protective gloves!



Feet

Wear foot protection!

A falling tool can cause injuries to the feet. Wear safety shoes with steel toe caps!



Head

Wear head protection!

Always wear a safety helmet if there is a danger of head injuries, especially from falling objects, during installation and dismantling work or crane operations.



Eyes

Wear eye protection!

We recommend the wearing of safety goggles if there is a possibility of harmful influences, such as strong light, chemicals, swarf, oil or dirt.



Hair

Wear a hair net!

Long hair and loose object, such as necklaces, can become caught in rotating machinery, such as the spindle or cooling unit rotor. Always wear a hair net to keep hair pulled back out of the way and remove any loose items, such as jewellery.

2.6 Safety Stickers on the Unit

Keep all safety and hazard instructions on the unit in a legible condition and adhere to them!



Warning!

Warning of non-ionising electromagnetic radiation!

Do not expose equipment sensitive to interference and people with active and, in certain cases, also passive medical implants to the unit's electromagnetic field.



Prohibited! Prohibited for persons with medical implants!

Do not allow personnel with active medical implants to work on this unit and, for safety reasons, ensure that they remain at a distance of 3 metres from the unit.



Warning!

Indirect danger to life in the switch cabinet!

The switch cabinet is designed to meet current standards, also in terms of contact safety within the cabinet. Nevertheless, mainly use suitable tools (e.g. measuring probes, screwdrivers) to touch voltages of 90 to 260 VAC!

Only open the switch cabinet when the unit has been made potential-free by switching off the main switch. A key is needed to open the safety lock.

Important note!



The switch cabinet does not contain any operating elements or fuses requiring manual operation. It is therefore unnecessary to open the cabinet in normal operation.

2.7 Hazard Points on the Unit and During Operation

Pos.	Dangerous point	Hazard	Safety instructions
1	Tool	Cuts	Wear gloves
2	Spindle	Crushing, danger of being caught	Avoid getting fingers jammed when inserting and loosening the tool! Wear clean gloves. Never wear loose objects, such as necklaces or other hanging jewellery, as they can become caught and pull the operator into the machine.

Table 1: Dangerous points on the unit

2.8 Dangers from Electrical Power / Voltage



Warning! Indirect danger to life if the unit is incorrectly operated!

- Never operate the unit if the case is open.
- Only permit **KELCH GmbH** specialists to open the case!
- Never operate the unit in a potentially explosive environment
- Never expose the unit to condensation or liquids.
- Immediately switch off the unit if the following damage occurs;
 - Loose cable connections,
 - Faulty insulation,
 - Burnt cables,
 - Other damage that adversely affects the electrical safety of the unit.
- Disconnect the presetter's mains plug prior to all maintenance, cleaning and repair work!
- Electrical shocks are still possible when the unit is switched off. Wait for approx. 5 minutes after switching off all poles (capacitor charge!) before touching the unit.
- Only operate the unit once all damage has been rectified.
- Only permit a qualified specialist to wire the unit to the mains power supply and work on the electrical equipment. It is imperative that all pertinent VDE guidelines, as well as guidelines and regulations applicable at the installation site, are adhered to.

2.9 Pneumatic Supply

Only allow qualified specialists to work on the pneumatic system in compliance with the guidelines and regulations applicable at the place of installation. **Kelch GmbH** waives all liability in the event of contravention.

2.9.1 Dangers from Hydraulic and Pneumatic Energy



Caution!

Risk of damage to property!

If damage to pressure hoses and cables, as well as threaded connections, is detected (e.g. abrasion marks or leaks), immediately switch off the tool presetter and only operate it again when the defect has been remedied.



Caution!

Danger of physical injury!

Danger of injury from the escape of high-pressure media

2.9.2 Danger from Lubricants



Warning!

Do not inhale oil vapours!

Oil vapours are harmful to health and can contain carcinogenic substances.



Warning!

Danger of slipping!

Hydraulic oils and lubricants on the floor and on machine parts can easily result in slipping. Together with sharp tools, they form a significant risk of injury. To prevent accidents, ensure scrupulous cleanliness when handling these liquids.



Caution!

Danger of burns and scalding!

Caution when handling hot operating and auxiliary substances!

Pay attention to the safety information on the product when handling oils, greases and other chemical substances.

2.10 Opening the Housing

Only permit Kelch GmbH specialists to open the tool presetter case!
Contravening this will result in KELCH GmbH waiving all liability.

3 Commissioning

3.1 Transport / Packaging / Storage

The measuring machine is mounted on a special pallet. A pallet truck or fork-lift can be used to transport it to its installation site.



The fork-lift truck must be capable of transporting a weight of 500 kg.

Please proceed as follows once it has been carefully placed on the floor:

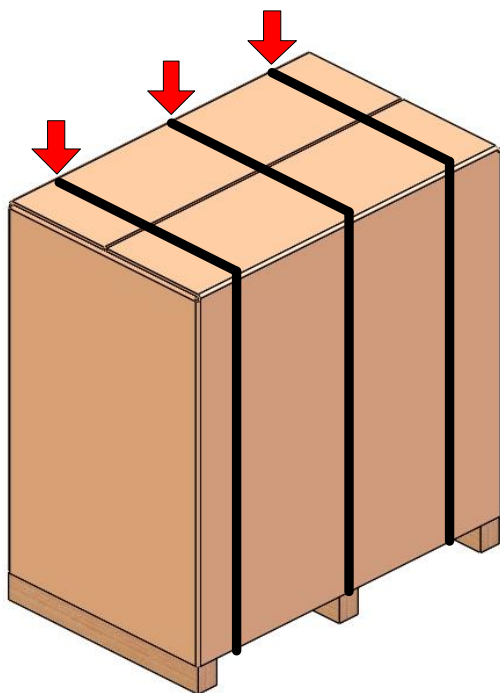

Remove the cardboard packaging

Cut through and remove the three packing straps and open the packaging.

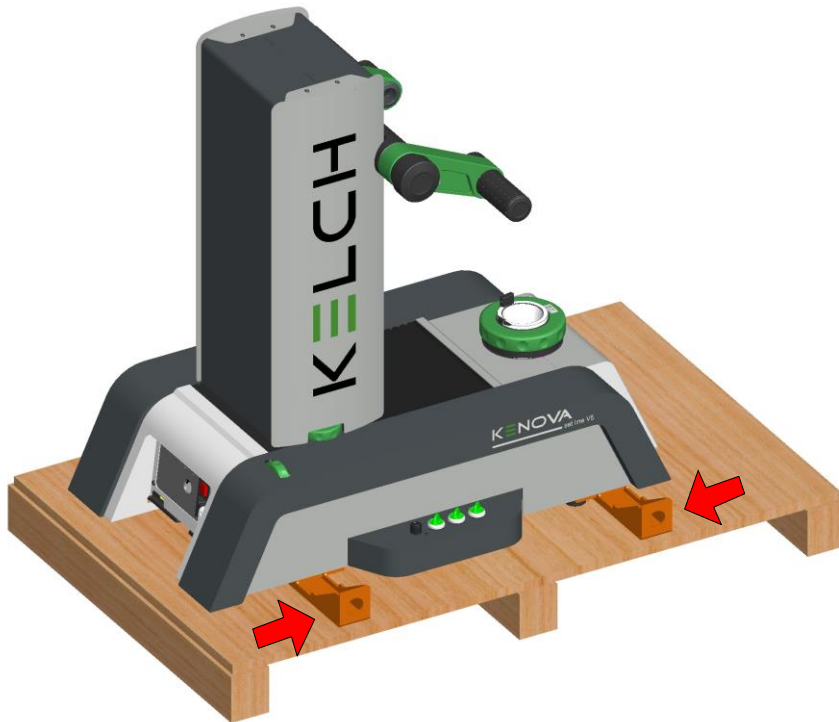

Figure 3 Example of the packaging

3. Commissioning

Remove the delivery bag, components and accessories container from the front of the packaging.

The measuring unit is attached to the base of the pallet by means of 2 transport fixings, which can then be used to lift it.



Remove the 8 screws from the transport fixings.

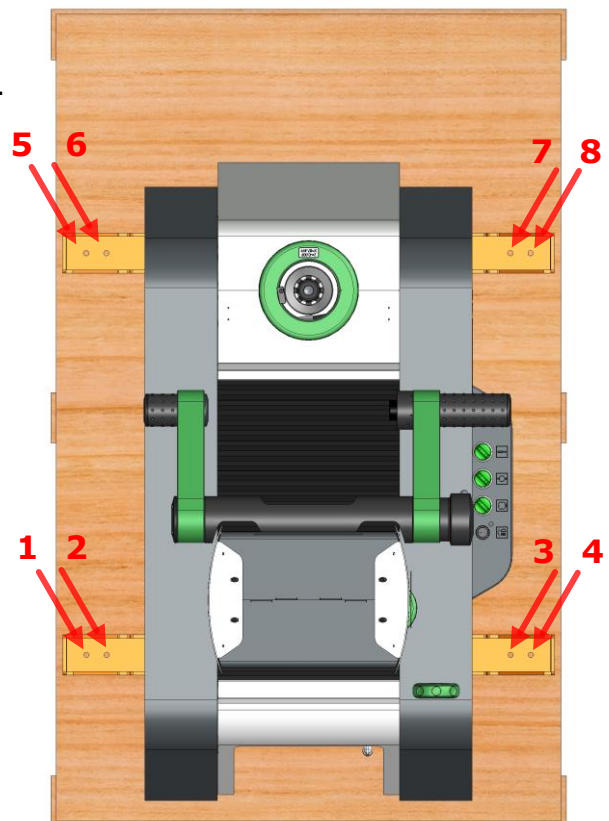

Figure 4 Unit fixed on the pallet

3. Commissioning

The machine can be lifted by the transport fixings.



Caution:

Please make sure that the 3 feet are correctly fixed in the recesses in the transport fixings.

Move the fixings in the direction of the arrow until they can go no further

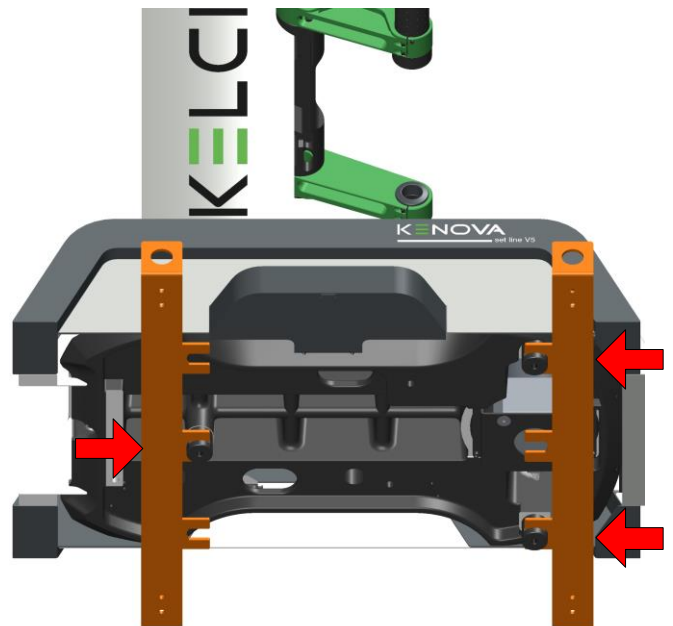

Figure 5 Positions of the transport fixings

Straighten the transport straps and carefully fix them into the 4 lugs on the fixings

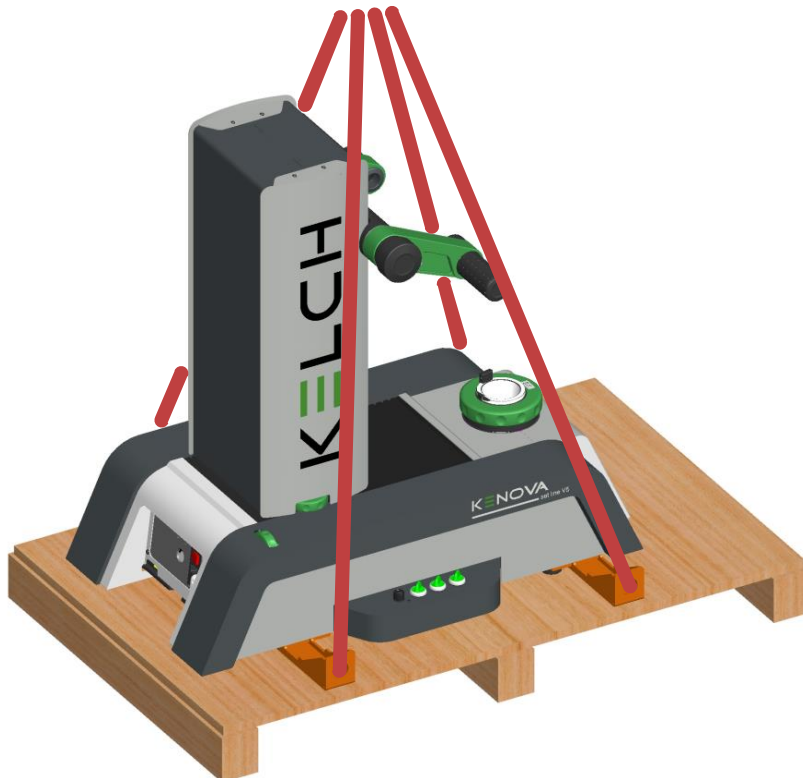

Figure 6 Fixing the transport straps

3. Commissioning

Please ensure the following before moving the machine into its final installation position:

Make sure that the installation site is capable of supporting the machine load including accessories.

Make sure that the installation site is sealed from dust and easy to keep clean.

Then slowly lift the machine into its final resting position and set down carefully.



Caution!

Risk of injury!

If the box is dropped it can cause injuries! Always make sure that the unit is standing firmly and is securely fixed during all stages of transportation!

Caution during unloading! It is essential to prevent impacts to machine components and ensure they are not dropped!

Make sure that the permitted load-bearing capacity of the crane is sufficient!

Make sure that chains, ropes, hooks and lifting eyes are in correct working order and also designed for the weight of the unit.

Refer to the Technical Data table in these instructions for the weight data. Use an appropriate haulage company to unload the unit if there is no suitable hoisting equipment available.

Never jerk the unit when lifting it!

Standing under a suspended load is prohibited and presents a danger to life!

Fit securing fixings for transportation.

If the unit is delivered in a transport container (shipping crate), make sure that all information required for unloading (hoisting points, crane load) is printed on the container.

Make sure that the film is not damaged during storage if the unit is shrink-wrapped! Otherwise, any warranty claims against **KELCH GmbH** will be invalidated!

3.2 Scope of Delivery

Upon receipt, immediately check the completeness of the delivery based on the despatch documents and packaging lists. The haulage company is liable for any damage during transportation!

3.2.1 Components of the KENOVA set line V5 new generation

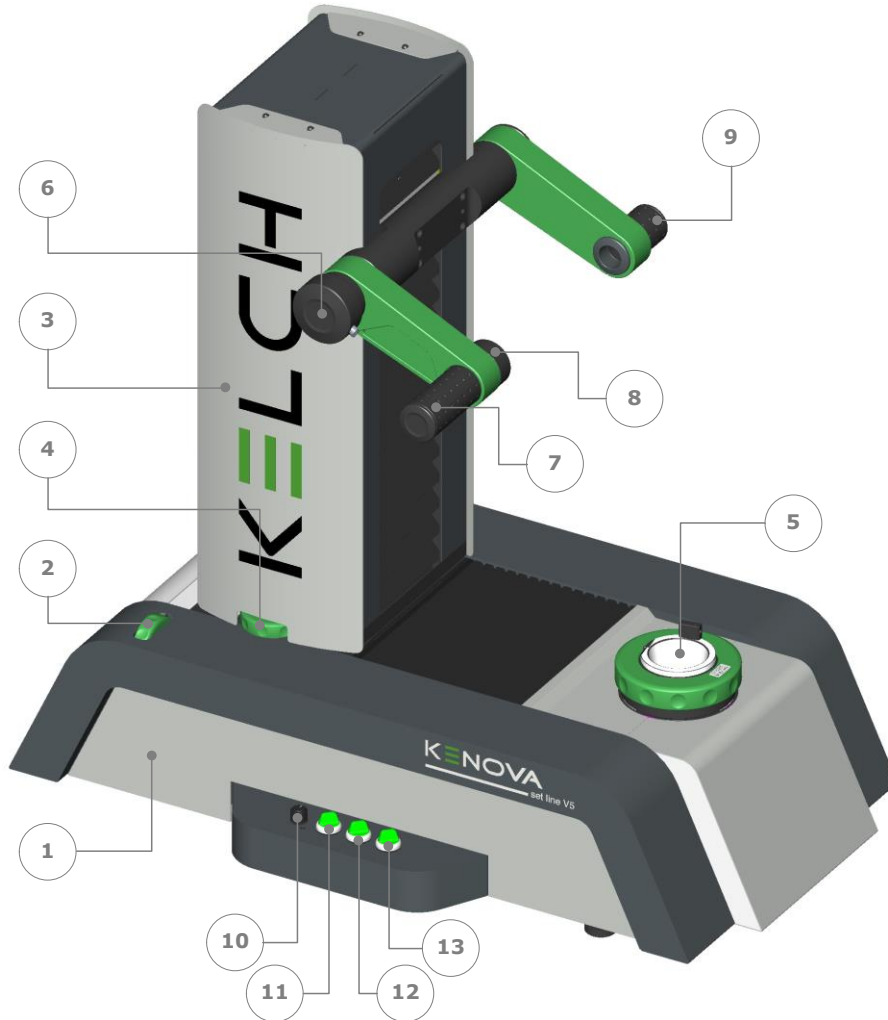

1	Base	11	Spindle brake 90° indexing button
2	Fine adjustment of the x-axis	12	Spindle brake button
3	Tower in the z-direction	13	Adapter locking button
4	Fine adjustment of the z-axis	14	
5	Spindle	15	
6	Rough manual adjustment of the x- and z-axis	16	
7	Camera with telecentric lens	17	
8	Top light	18	
9	Telecentric transmitted light	19	
10	Top light control	20	

Figure 7 Components of the KENOVA set line V5 new generation

3.3 Commissioning and Removal of the Transport Fixings

The measuring system is fitted with transport fixings to prevent damage to the moving parts. Make sure that the axes are secured every time the machine is transported. There are 4 securing points shown in the figure below. Remove the axis fixings in the following order:

- 1 x-axis fixing
- 2 x-axis fixing
- 3 z-axis fixing
- 4 z-axis counterweight fixing

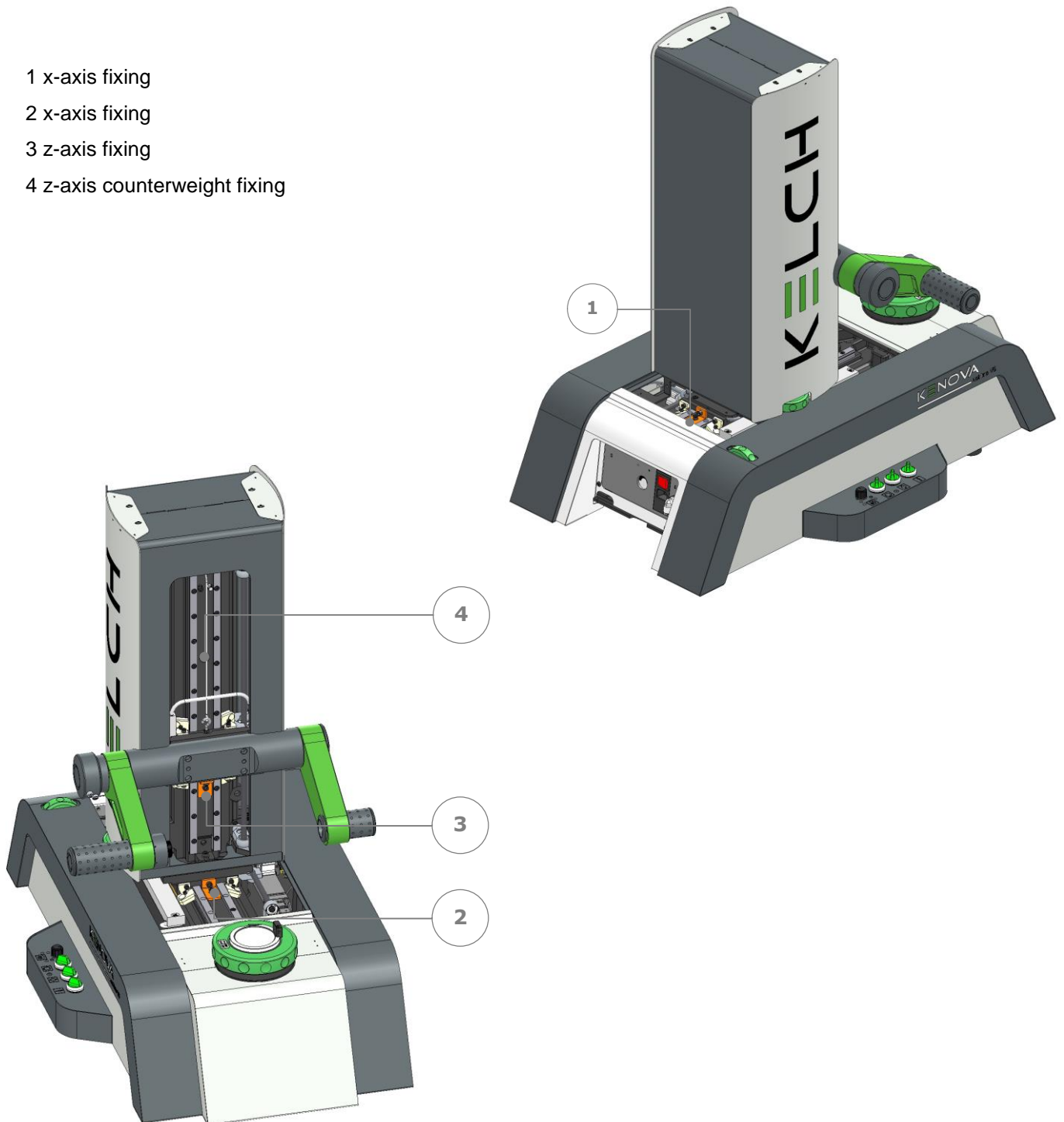

Figure 8 Positions of the transport fixings

All the transport fixings can be removed once the unit has been transported into its final position.

Remove the dust bellows in the areas shown to access the fixings for the x and z-axis. They are covered by a dual-lock fabric. Completely remove the locking screw in position 4. Keep the fixings in a safe place for future transport of the unit.

3.4 Installation

The unit is delivered as a ready-assembled unit. Horizontal adjustment is needed during installation.



Important note!

Use the adjustment feet and a spirit level on the flat face of the spindle to make sure that the base is horizontal (0.05/1000 mm) in both directions (move the spirit level horizontally by 90° to check).

3.5 Mains Connection

The KENOVA V5XX unit requires 220-240 V~ 50/60 Hz, single-phase. The unit has a power consumption of 0.5 kVA.

Make sure that the mains cable is inserted into the connector under the mains connector, see position 1.

Connect the other end of the cable to the mains power supply, taking into account the necessary safety measures in line with the prevalent regulations.

Make sure that the cable is properly connected.

Press the mains power switch, pos. 2. The red light should come on.

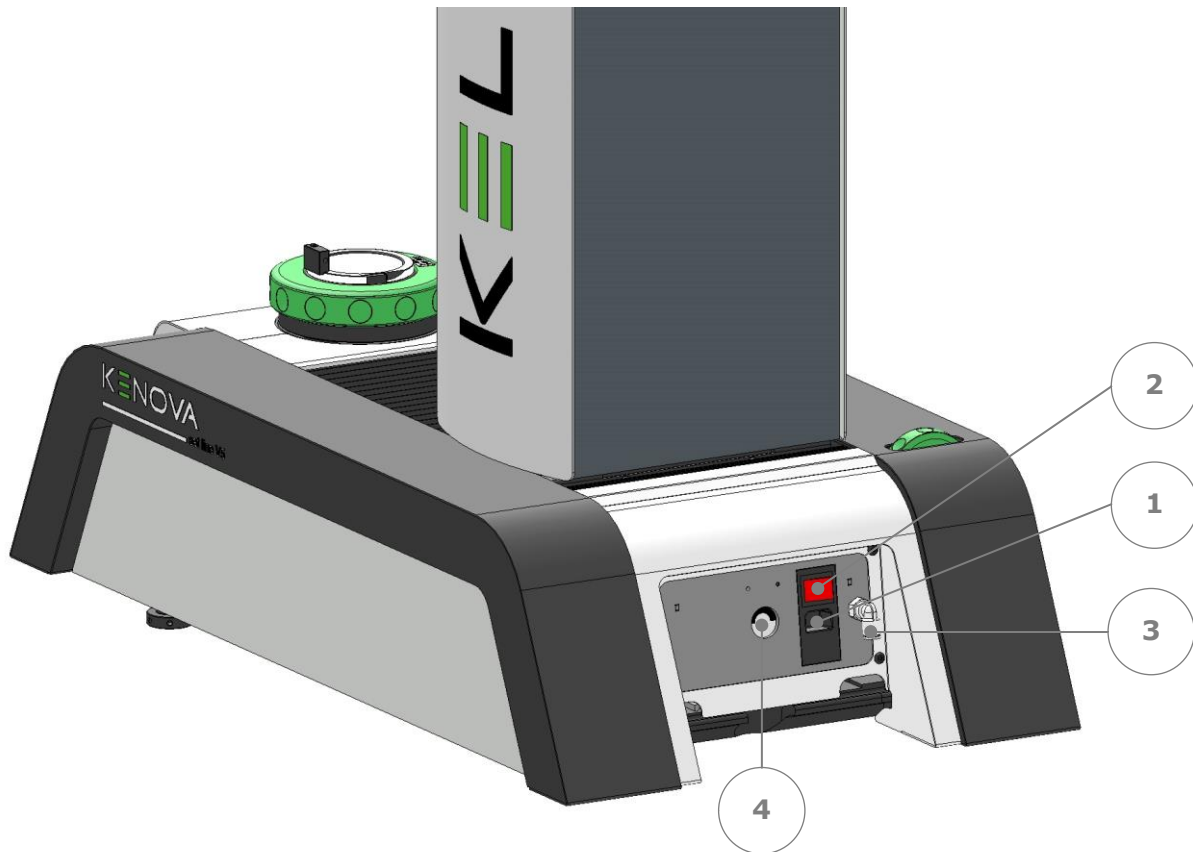

Figure 9 Visualisation of the electrical and pneumatic connections

Presetter:

Europe single phase 1~, N, PE 230 V, 50 – 60 Hz; 2.5 kW (L1, N, PE),
3-pin Schuko connector

England UK single phase 1~, N, PE 230 V, 13 A; 50 – 60 HZ, 1 kW,
3-pin PD1 – 13 A

USA single phase 1~, N, PE 115 V, 15 A, 50 – 60 Hz; 1.7 kW (L1, N, PE),
3-pin NEMA 5 – 15 P UL817/CSA22-2 (125 V / 15 A)

Use a country-specific (e.g. Euro/USA) connector to connect the unit to the mains power supply in the workshop.



Important note!

The main switch is located on the front of the unit.

Load rating for the unit

Power connection 90 – 260 V, 47 – 60 Hz, standard 16 A mains fuse,
power consumption of the unit approx. 0.5 kVA.

3.6 Pneumatic Connection

The compressed air connection is needed to activate the automatic axis lock.

Connect the hose connection to your compressed air network to the 1/4" fixing (pos. 3). Use a pressure gauge to check the pressure (Pos. 4). It should be between 5 and 7 bar. The estimated air consumption is 100 nl/h.

3.7 PC Connection and Peripherals

Make sure that the main switch is off.

Proceed as follows to connect the peripherals

Different inputs are available to connect the peripheral components to the PC. All connectors comply with the safety provisions and regulations.

Make sure that the unit is connected in accordance with the installation description provided.

The PC offers 8 USB ports. (6 on the rear of the unit, 2 on the front)

Important:

Make sure that the USB connectors are inserted into the appropriate positions to ensure the correct operation of the system.

The PC ports and the cable connectors carry the same labels.

The following symbols are used to identify the unit connectors:

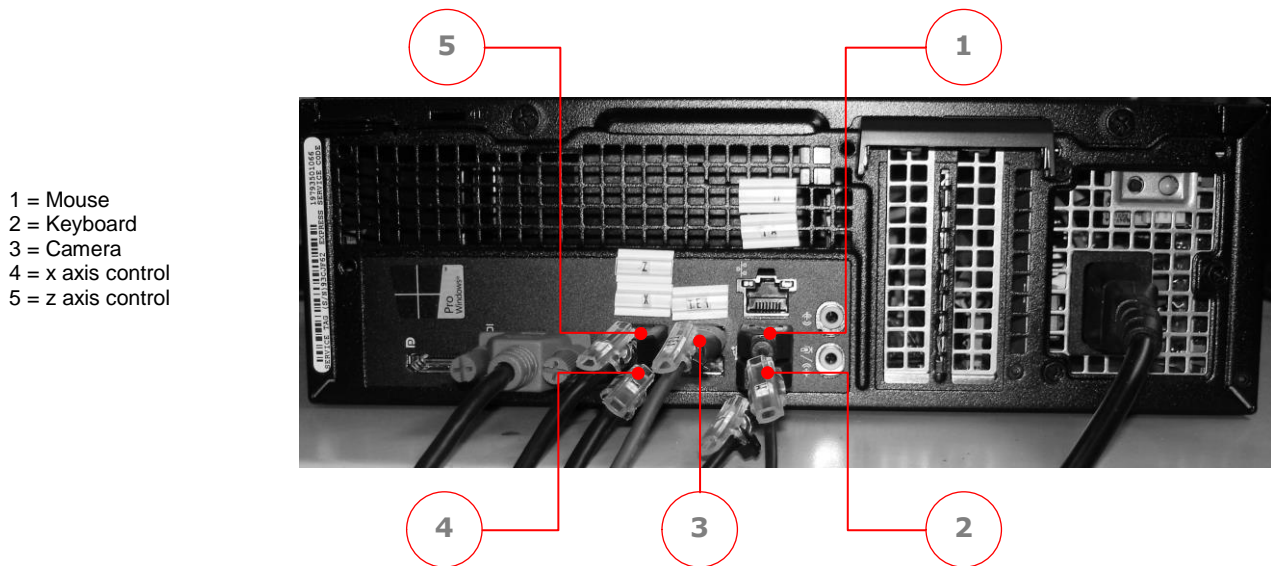

Figure 10 Assignment of ports on the PC

Finally:

- Connect the mains cable of the KENOVA set line V5 new generation to the mains power supply.
- Press the mains switch. The red light should come on.

3.8 Handover

All KENOVA set line V5 new generation series units are checked by **Kelch GmbH** specialists for compliance with the geometry prior to shipment. A data log is produced. The data log is supplied with the machine. A maintenance sticker is located next to the nameplate.



Important note!

Kelch GmbH accepts no responsibility for the specified measuring accuracy of the unit without a valid data log!

4 Switching On and Getting Started

The main switch (Pos. 1) is located on the front of the unit.



Figure 11 Mains switch

The switch (1) is used to switch on the machine. The 'On' button lights up when switched on. The PC and monitor are switched on separately.

Once the PC has booted up and the control and analysis program has started, a prompt appears on the monitor asking you to reference the axes. Follow the instructions on the screen.

4.1 Referencing the Axes (Homing)

Reference the axes, also known as homing, by manually moving the x- and z-axis. The procedure is explained below:

Press the tool power button (see Chap. 5.4) before switching on the machine.

The prompt shown below to reference the axes appears as soon as the machine is switched on and the analysis program has been started:

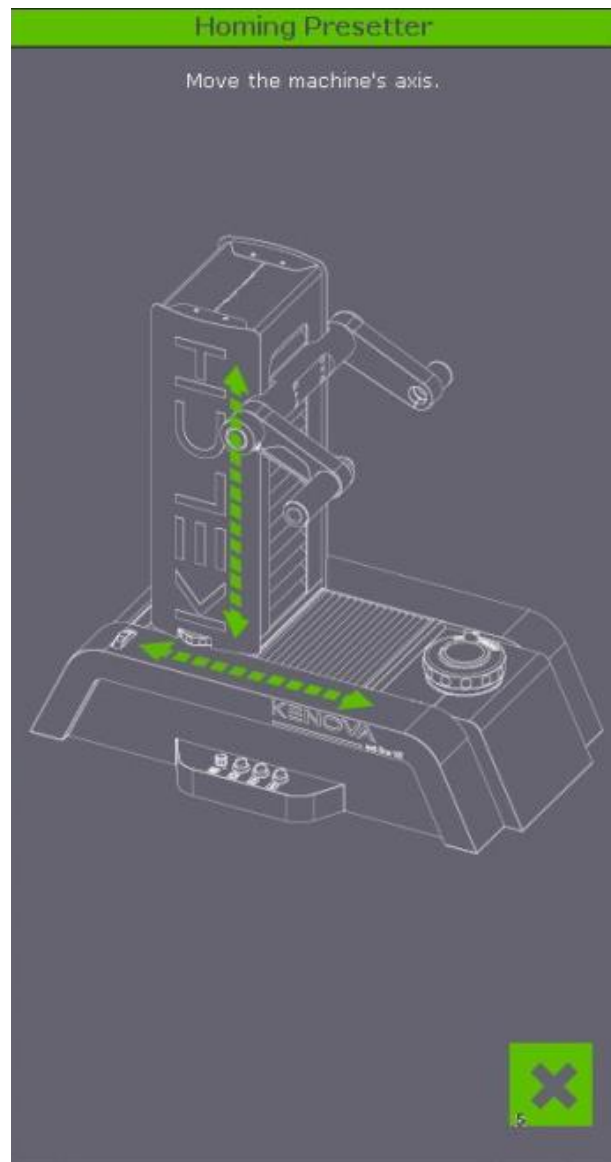

Figure 12 Information for axis referencing

4. Switching On and Getting Started

Proceed as follows to move the axes:

Follow the above instructions on the monitor and press both buttons (X) and (Z) on the handle

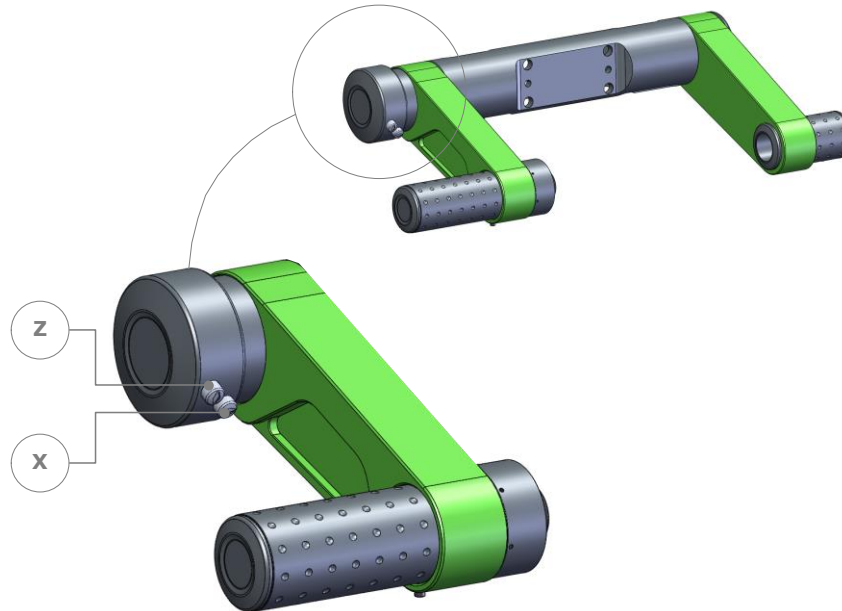

Figure 13 Camera light holder with handle

This releases the axes brakes.

Press and hold down both buttons and move the axes approx. 30 mm in the \pm direction of the respective axis.

As soon as the axes have been referenced, i.e. the axis positions are recognised by the system as being valid, the colour of the axis position display changes from blue to green and the current axis position is displayed. The above prompt window disappears and the axes have both been correctly referenced.

(*) Optional:

If the machine has a CNC spindle drive, then the rotary axis is referenced automatically

This procedure needs to be performed each time the PC is switched on.

4.2 Calibration Process

A reference notch is located on the outside of the tool holder on the spindle, which indicates a cutting edge of a tool insert (Pos. 1).

A plate is attached to the spindle wheel (Pos. 2), which carries the reference values that define the zero position of the machine.

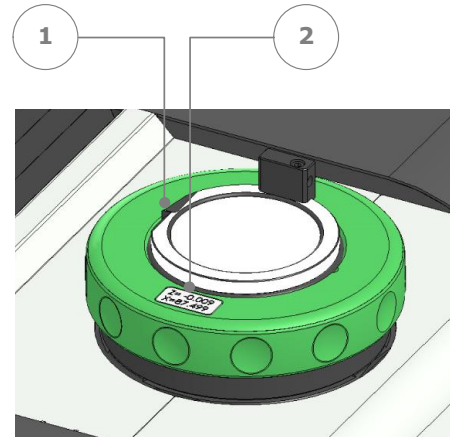

Figure 14 Plate with zero point coordinates

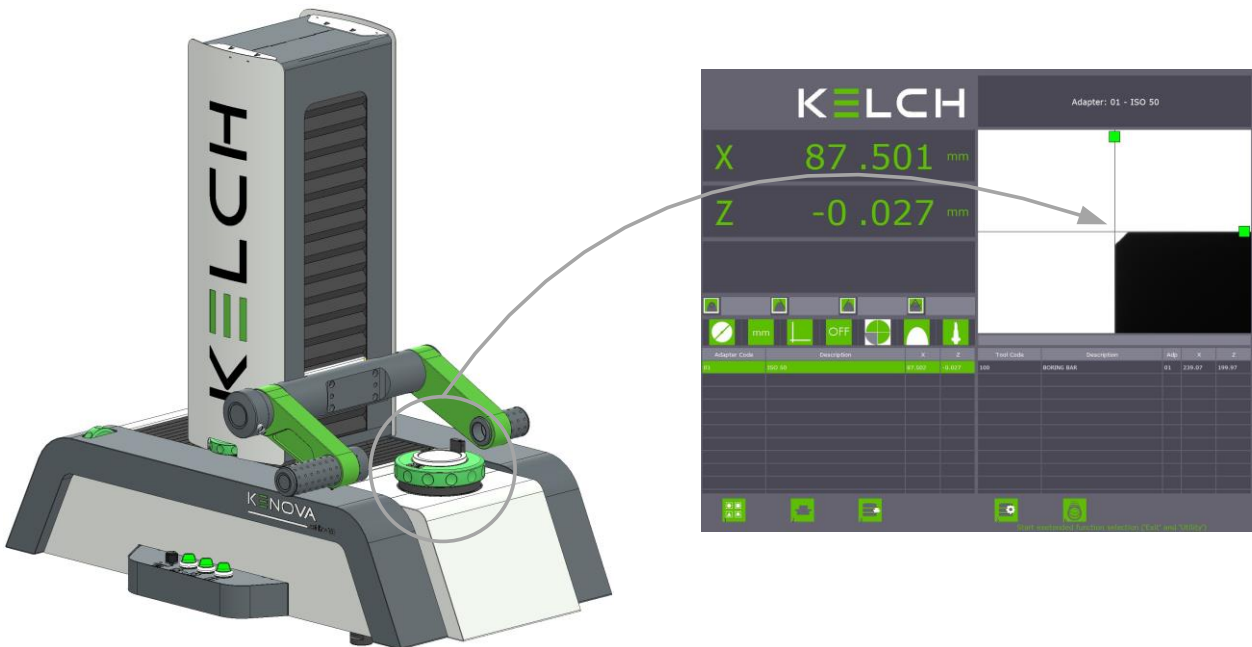

Figure 15 Visualisation of the reference notch

Proceed as follows to calibrate the machine:

Move the axes so that the reference notch appears in the centre of the image in the live image display on the monitor, see below.

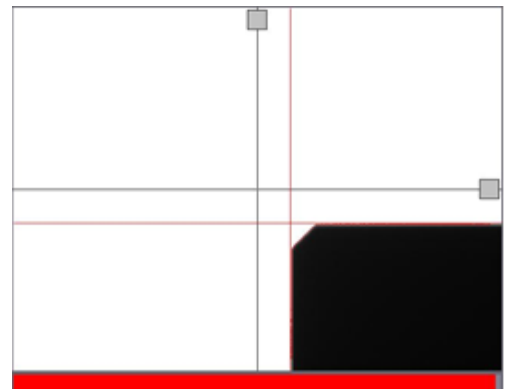

Figure 16 Reference notch not in focus

Thoroughly clean the reference notch to obtain a good calibration result.

Focus the reference notch by moving the spindle wheel until you have obtained optimum focus (visual adjustment). Optimum focus has been achieved when the red ribbon in the live image display changes from red to green, as shown below.

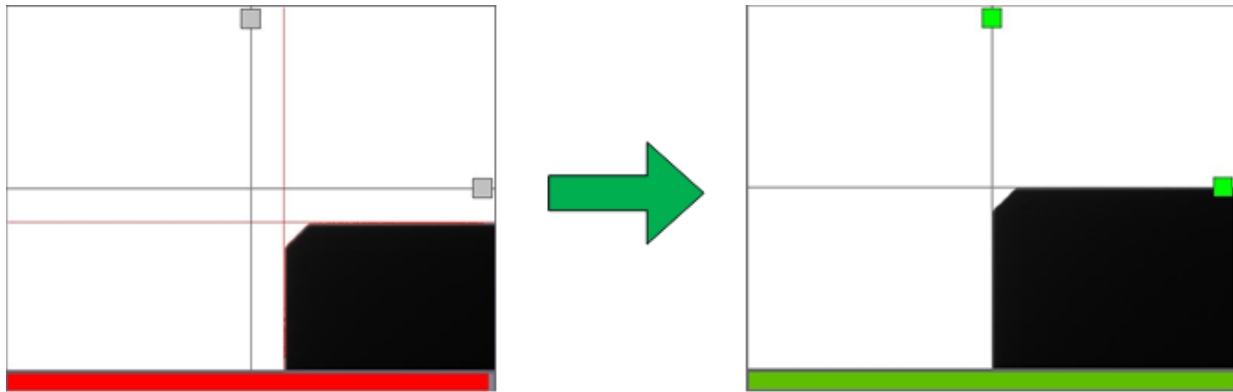

Figure 17 Focussing procedure

Use the software function provided for calibration. The software description describes its use.

(*) Optional

If the system has a CNC spindle, enable the Auto-Focus function in the operating program once you have positioned the reference notch (Figure 16). The software description describes its use.

Verifying calibration

Use the spindle wheel to rotate the reference notch into the optimum focus position. The x- and z-value measured in the axis display should correspond to the value on the plate on the top of the spindle wheel.

4.3 Properties and Use of the Control Panel

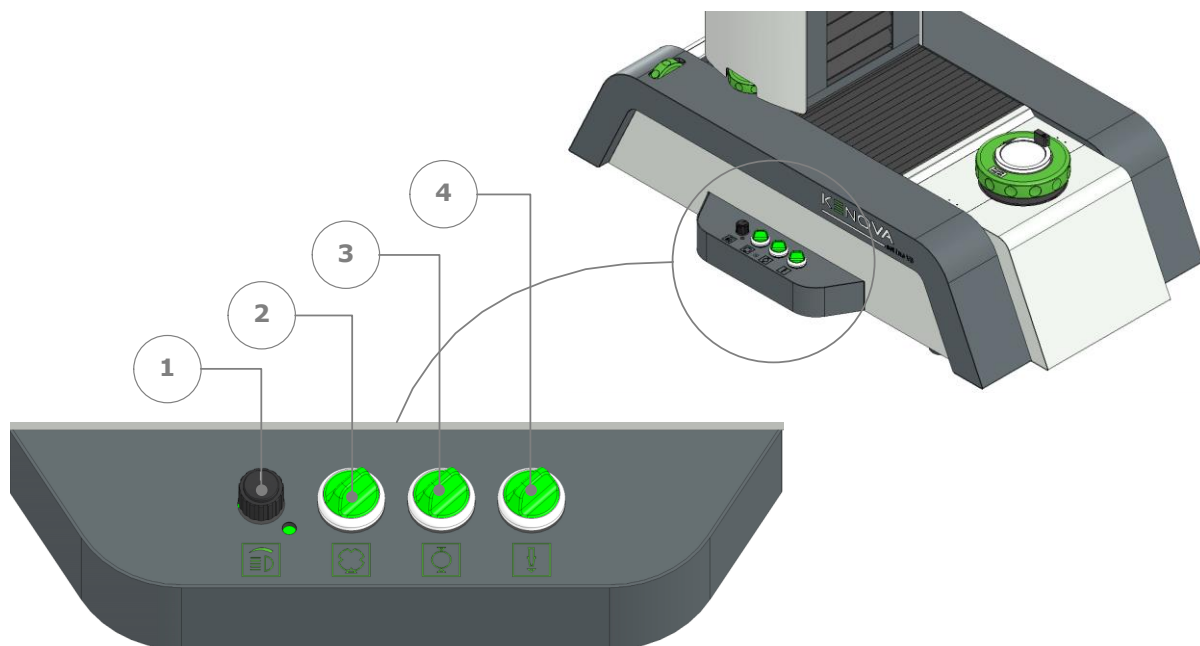

Figure 18 Control panel

4.3.1 Use of the Automatic Tool Clamp (4)

The automatic tool clamp fixes the tool holder in the spindle (adapter lock). KELCH offers the corresponding adapters for different tool holder types.

Actuating the adapter lock:

Actuate the adapter lock by turning the switch (4) on the control panel to the right.

4.3.2 Using the Spindle Brake (3)

The brake prevents accidental rotation of the focussed workpiece before and after measurement.

Activating the brake:

The brake is activated by turning the switch (3) on the control panel to the right. The spindle can be fixed in any desired position.

4.3.3 Using the Spindle Brake with Indexing (2)

The spindle brake with indexing enables the rotational position of the spindle position to be fixed in precise 90° increments:

Use and activation of spindle indexing:

Activate spindle indexing before a measurement.

Rotate the spindle in the vicinity of the desired index position

The index brake is activated by turning the switch (2) on the control panel to the right. Search for the engaging position by cautiously rotating the spindle in both directions.

Deactivating the index brake:

Deactivate the index brake by turning the switch (2) on the control panel to the left.



Caution!

Do not forcefully turn the spindle when it is engaged to ensure that indexing functions precisely.

4.3.4 Use of the Top Light

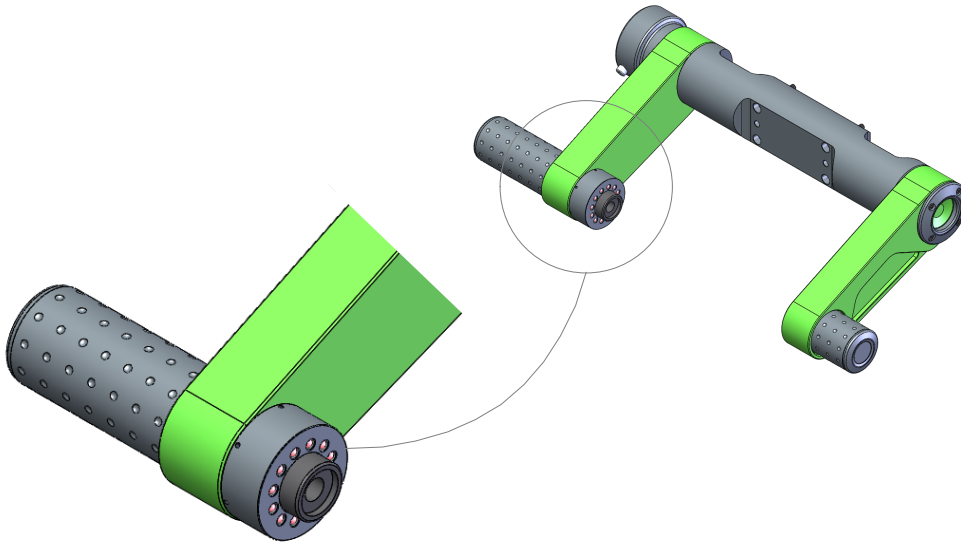

Figure 19 Camera and light holder

The top light consists of an LED ring light fixed to the outside of the camera lens. This ring light can visually analyse the surfaces of cutting edges and tools in the image processing system.

It is used to detect possible damage and defects that cannot be detected in the back light. The ring light is fixed in the direction of view of the camera to ensure simple positioning and placement.

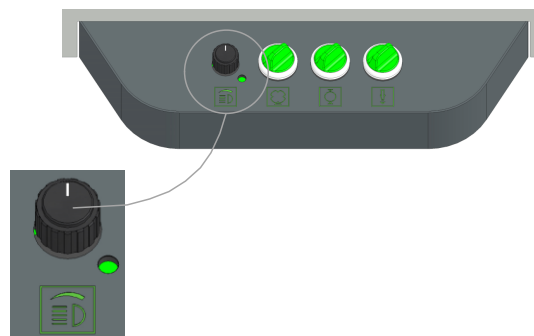

Figure 20 Output control of the top light

The output control on the control panel can adjust the light intensity to improve image contrast and reduce reflections from a cutting edge.

The output control includes a switch to switch on the ring light, and regulates contrast and visibility.

When an LED close to the rotary button lights up it shows that the switch is switched on. (The ring light is switched on). The light is regulated by rotating the knob. Maximum brightness is obtained by turning the knob clockwise.



Note:

Infra-red (IR) LEDs are used for all lights. Their light is not visible to human eyes. The LEDs can only function properly if the in-built camera, which is sensitive to IR, is fixed in place.

4.4 Inserting a Tool into the Spindle

Make sure that the tool holder is clean, cleaning it if necessary.

Make sure that the spindle insert and tool holder are matched to each other, including the clamping bolt.

- Make sure that the main switch is on.
- Insert the tool from above into the adapter sleeve. Ensure that no swarf or other dirt penetrates into the presetter!
- Use the switch on the control panel to position and lock the tool (see also Chap. 4.3):
 - The **spindle brake** turns on/off the spindle brake
 - The **Lock** switch switches the spindle lock on/off (90° increments)
 - The **Adapter lock (1)** clamps and releases the tool in the spindle holder

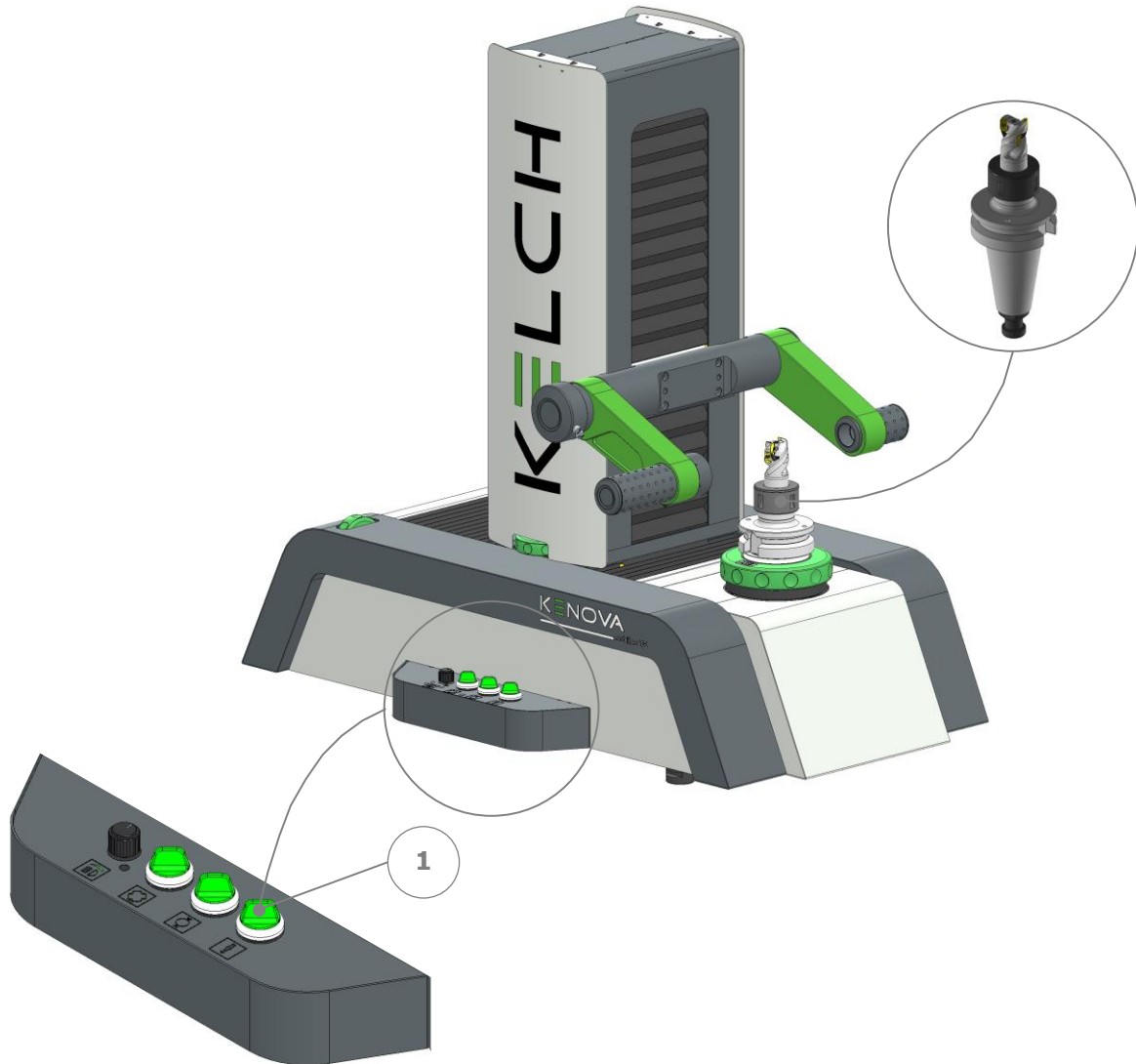

Figure 21 Inserting the tool and clamping with the adapter lock

The tool can now be measured.

4.5 Tool Presetting and Measurement

The user can continue with measurement and checking once the tool has been calibrated and inserted into the spindle holder:

- Position (roughly) the part of the tool to be measured in front of the camera by releasing the axes by means of the two buttons on the handle and simultaneously moving the camera position

4. Switching On and Getting Started

- Use the micrometre adjustment (X) and (Z) to precisely position the axes
- Focus the tool in the camera image by rotating the spindle

(*) Refer to the description of the software for instructions on using the CNC spindle

- Once the tool is focussed (green focus bar), the spindle can be locked at this angle by activating the spindle brake.
- The brake is applied by turning the switch (1) to the right
- The measured result is displayed on the monitor.

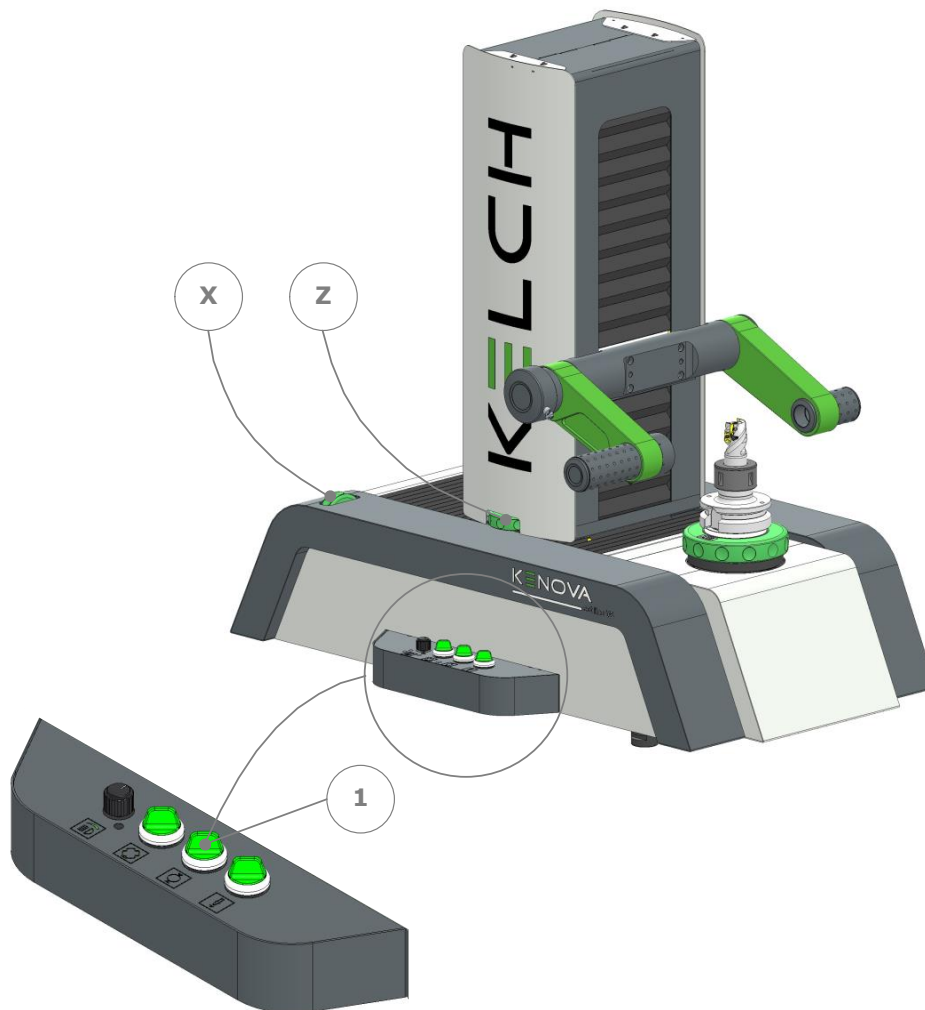

Figure 22 Operating the spindle brake

4.6 Switching Off the System

Proceed as follows to switch off the system:

- Remove the tool from the spindle insert (*).
- Insert the plug into the spindle.
- Power down the PC as described in the separate operating instructions.
- Use the main switch (1) to switch off the machine. The switch light turns off.

(*) Tool is understood as being the combination of a processing tool in the corresponding chuck.

4.7 Instructions for Using the Machine



Caution!

Possible damage to the setting drives!

Swarf, sand and other forms of dirt can damage the setting drives for the X- and Z-axes.



Important note! Keep the contact surfaces between holder (1) and adapter (2) absolutely clean!

The tiniest particle of dirt makes the measurement unusable!



Important note! Measurement errors caused by thermal expansion can be avoided if the tool is at ambient temperature.



Caution!

Incorrect and improper operation can result in possible injury and material damage!

Make sure when moving the camera/lens holder that the entire path is unobstructed! Do not reach into the camera/lens path to avoid injury from getting caught! Objects that get caught can be damaged and damage the unit's setting drives!



Caution!

Damage to the headstock is possible!

Only rotate the engaged spindle in the **Lock Off** position!

5 Maintenance and Care

5.1 Safety Measures

Make sure that the following basic safety precautions are adhered to before beginning maintenance and repair work:

- Position the tool adapter so that the area to be worked on can be accessed without problem.
- If necessary, provide support for vertical slides and similar machine parts.
- Switch off the machine.
- Switch off at the main switch and use a padlock to secure against inadvertent restarting.
- Also switch off any external power supplies, if applicable.
- Depressurise hydraulic and pneumatic systems.
- Cordon off an extensive repair area as required!

During repairs:

- It should not be possible for the machine to move,
- There should be not media under pressure,
- The electrical equipment should be de-energised.

Only allow persons who have had expert training in this type of work to carry out maintenance and repair work.

Comply with the setting, maintenance and inspection work and the prescribed intervals specified in these instructions for the replacement of operating materials and wear parts!

Inform operating personnel before commencing special work and repairs. Nominate a supervisor!

When replacing larger modules, carefully fix and secure them to lifting equipment.

Refer to the safety regulations in Chapters 2+3!

Use ladders, any other safe means and working platforms for installation work above head height. Do not use parts of the machine as climbing aids!

Wear a safety harness when carrying out maintenance work at a height! Keep all handles, railings, platforms, staging and ladders free from dirt and lubricants!

Appropriate equipment is essential for maintenance.

Always re-tighten any screw connections that have been loosened once maintenance and repair work has been completed!

Immediately replace any guards and safety equipment that has been removed for maintenance and repair work once maintenance and repair work has been completed and check that it is in correct working order. Before handover to operating personnel, i.e. switching from manual to automatic mode, remove all keys from the operating panel and keep them safe!

This safety measure ensures that the machine's functions cannot be activated by unauthorised persons.

5.2 Inspection

A monthly visual inspection of operations is needed to detect possible damage in good time and ensure uninterrupted production.

5.3 Cleaning

Make sure that the functional parts of the unit remain clear of swarf.

Ensure the correct operation of the unit by regularly it with a soft, lint-free cloth and lubricating metal surfaces with a little preservative, such as silicone oil. A cold-cleaning agent is preferable for cleaning the machine components.

A commercially available glass cleaner can also be used for obvious dirt.

Corrosion protection is applied to machine components when delivered.

Never use chlorinated hydrocarbons, such as PER, TRI or similar, to clean machine components or remove the corrosion protection.



Caution!

Risk of damaging the unit

Under no circumstances use a steam jet, water jet or compressed air! There would be a risk that dirt and cleaning agent could penetrate into the guides and seals. This could cause functions – particularly safety functions, limit switches or measurement systems – to be disabled.



Caution!

Danger of fire

Clean the unit outdoors and take special precautions if benzine is used.



Important note! Collect any cleaning liquid that runs off and dispose of it professionally

5.4 Maintenance

All roller bearings are lubricated for life.

Any grease nipples are standard elements on the corresponding components. Additional lubrication is not needed because of the low loading. We recommend that you arrange for KELCH specialists to carry out maintenance work to meet the expected long-term precision requirements and outstanding.



Important note! Only allow Kelch GmbH specialists to undertake annual maintenance work!

Regularly inspect pressure hoses and cables, as well as their screw fittings, and immediately replace them – even at the slightest signs of damage.

5.4.1 Maintenance Schedule

Copy the following maintenance schedule and use it as a check-list. Once the work has been completed, date and sign the completed page and use as a record of the work.

Maintenance work	Maintenance interval					Result	
	Daily	Weekly	Monthly	Yearly	Every 2 years	OK	not OK
Check protective cover	X						
Check guide cover bands for damage	X						
Check the maintenance unit setting (5 bar)	X						
Inspect air lines and valves for leak-tightness		X					
Clean or replace the air filter (PC)			X				
Check the counterweight cables, pulleys and axles for damage. Replace damaged components				X			
Check the run-out of the tool holder				X			
Check that the taper holder is parallel to the longitudinal guide.				X			
Check the focus setting of the camera				X			
Check the setting of the light source; readjust if necessary				X			
Check the counterweight cables. Check the shaft and pulley for wear. Replace parts if worn					X		

Lack of, or poorly performed, maintenance of the system can result in the following:

- Kelch GmbH specialists
- Reduced operational safety
 - Unnecessary down times
 - Avoidable repair costs
 - Shortened service life

We recommend that maintenance is carried out by

Tel: +49 7151 20522-500

Fax: +49 7151 20522-11

Date:

Signature:

6 Technical Data

6.1 Measuring Ranges and Unit Dimensions

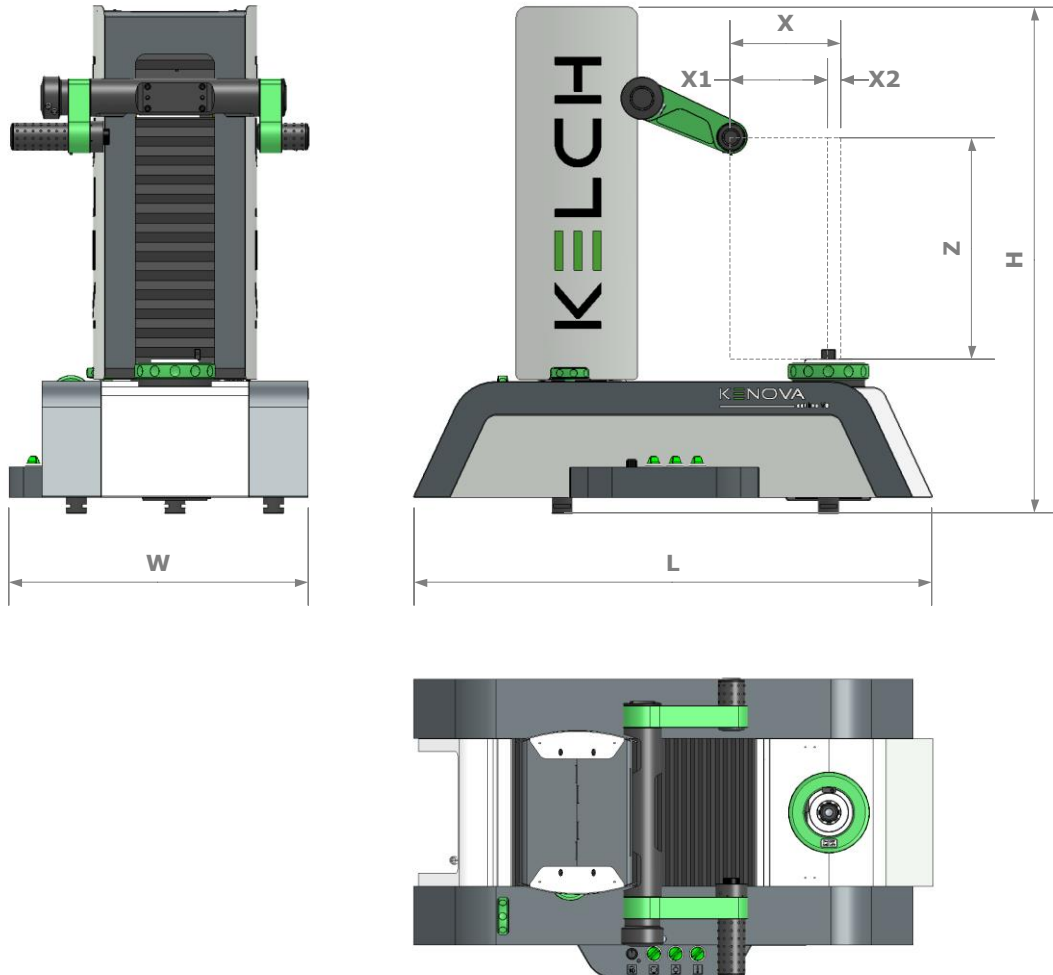

	K Set V544	K Set V545 • System optionally available	K Set V546
Measuring range of the x-axis	203 mm (X1=178 + X2=25)	203 mm (X1=178 + X2=25)	203 mm (X1=178 + X2=25)
Measuring range of the z-axis	400 mm	500 mm	600 mm
Max Ø	350 mm	350 mm	350 mm
Max. path in Z	400 mm	500 mm	600 mm
H	930 mm	1030 mm	1130 mm
L	950 mm	950 mm	950 mm
W	545 mm	545 mm	545 mm
Weight	230 kg	250 kg	270 kg

Table 2: Measuring ranges of KENOVA set line V5 new generation

6.2 Connection and Consumption Figures

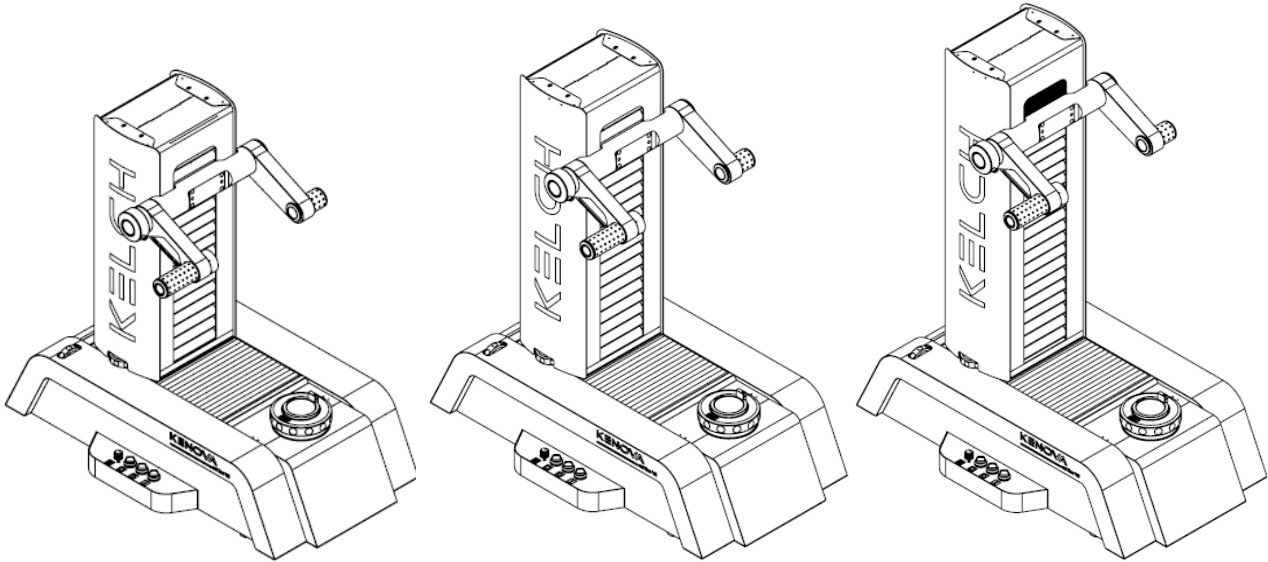

	K Set V544	K Set V545 • System optionally available	K Set V546
Electrical connection values			
Voltage range	100...240 V~	100...240 V~	100...240 V~
Power consumption	0.5 kVA	0.5 kVA	0.5 kVA
Frequency	50/60 Hz	50/60 Hz	50/60 Hz
Pneumatic connection values			
Pressure	5 – 7 bar	5 – 7 bar	5 – 7 bar
Consumption	100 nl / h	100 nl / h	100 nl / h
Connection	1 / 4"	1 / 4"	1 / 4"

Table 3: Connection and consumption values of the KENOVA set line V5 new generation