

Tool Adjusting Device SECA Operating Instructions



Document order no.: 1045386

© Kelch & Links GmbH 2006
All rights reserved
Subject to technical changes

Table of Contents

1	Product Liability and Warranty	4
1.1	General Information.....	4
1.2	Warranty.....	4
1.3	Maintenance.....	5
1.4	Intended Use.....	5
1.5	Disposal of the Device.....	5
2	Safety	6
2.1	Warnings and Hazard Symbols.....	6
2.2	Basic Safety Regulations.....	6
2.3	Spare Parts, Accessories.....	6
2.4	Requirements for Operating and Maintenance Personnel.....	7
2.5	Protective Clothing.....	7
2.6	Safety Stickers on the Device.....	7
2.7	Danger Zones at the Device.....	8
2.8	Dangers of Electrical Energy.....	8
2.9	Compressed Air Supply.....	8
2.10	Opening the Casing.....	8
3	Operation	9
3.1	Components.....	9
3.2	SECA Variants.....	10
3.3	Measuring Carriage.....	11
3.3.1	Projector.....	11
3.3.2	Camera.....	11
3.4	Preparation for Measurement.....	12
3.5	Measuring Radius (X) and Length (Z).....	14
3.5.1	Projector Version.....	14
3.5.2	Camera Version.....	15
3.6	Completing the Measurement.....	15
3.7	Saving the Adapter.....	15
3.8	Technical Data.....	16
4	Initial Operation	17
4.1	Transport/Packaging/Storage.....	17
4.2	Scope of Delivery.....	17
4.3	Transport Safety Devices.....	18
4.4	Cleaning.....	19
4.5	Assembly.....	19
4.6	Pneumatic Connection.....	20

4.7	Electrical Connection	21
4.7.1	Cable for Connecting the Control Device.....	21
4.7.2	MICRO	21
4.7.3	Micro Vision.....	22
4.7.4	EASY, EASY Vision	22
4.7.5	Procedure for Cabling	23
5	Maintenance and Service	24
5.1	Cleaning	24
5.2	Maintenance.....	24
5.3	Spare Parts, Accessories.....	26

Table of Figures

Fig. 3-1:	SECA operating and display elements (without control device)	9
Fig. 3-2:	Inserting the receiving sleeve (accessories) into the ball-type nipple (SECA C only)	12
Fig. 3-3:	Inserting the tool (in this example, a setting mandrel)	12
Fig. 3-4:	Positioning the tool (SECA C left, SECA E right)	13
Fig. 4-1:	Pneumatic diagram, vacuum (1) for headstock only SECA E	20

1 Product Liability and Warranty

1.1 General Information

These Operating Instructions are important to operate the device safely, properly and economically. Observing the operating instructions helps to avoid risks, reduce repair costs and downtimes and to increase the reliability and service life of the machine as a whole.

Note: The operating instructions for the control device are supplied as a separate document, but the contents should be regarded as part of this document.

These Operating Instructions, especially section "Safety", page 6, must be read and applied by each person who works with the device:

Operation

Including loading, fault clearance in the workflow, elimination of production waste, maintenance, disposal of operating and auxiliary materials.

Maintenance

Maintenance, inspection and refurbishment.

Transport

In addition to the Operating Instructions and the statutory accident prevention regulations applicable in the country of use and at the installation site, the recognized technical rules for safe and proper working should be observed, as well as the specific rules prevailing at each site.

If you have any questions, please do not hesitate to contact us, **Kelch & Links GmbH**.

Kelch & Links GmbH

Wiesenstraße 64
D-73614 Schorndorf

Phone: (+49)7181 925 0 Head office
 212 Hotline
 213 Service

Fax 220

Email: info@kelch.de

Internet: www.kelch.de

1.2 Warranty

The device's performance, operating safety and precision is expected to last for many years. However, this can only be ensured if the regulations regarding operation and maintenance are complied with.

During the warranty period, any faults that occur will be cleared in accordance with the warranty terms defined by **Kelch & Links GmbH**. All consequences of unauthorized alterations and changes shall be at the expense of the operator. This applies in particular to such changes that affect the device's safety.

The warranty applies only to original spare parts.

These Operating Instructions do not extend **Kelch & Links GmbH's** terms of sale and delivery!

1.3 Maintenance

We strongly recommend that you keep in stock the most important spare parts and parts that are subject to wear (see section "Spare Parts, Accessories", page 26) .

1.4 Intended Use



- | | |
|---------------|-----------------------|
| 1 Tool | 3 Holder with adapter |
| 2 Tool holder | 4 SECA |

The Tool Adjusting Device SECA is used for measuring tools. The term tool is used to refer to the **complete tool**, that is, a tool (1) in its tool holder (2).

The temperature of the tool must be approximately the same as the ambient temperature. Tools in previously heated shrink fit chucks must cool down before they can be measured.

Any other or additional use does not constitute the intended use of the device. **Kelch & Links GmbH** shall not be liable for any damage resulting from this and the operator bears the risks of this alone.

The intended use also includes the observation of the Operating Instructions as well as the compliance with the inspection and maintenance intervals prescribed by **Kelch & Links GmbH**.

1.5 Disposal of the Device

During device construction, special attention was taken to ensure that - where possible - no compounds were used. This construction concept allows for a high degree of recycling at the end of the device's service life. We can therefore also offer to take back the device and to dispose of it properly.

Furthermore, we would like to point out that you must comply with the obligations of the *Elektronikschrott-Verordnung* [German ordinance on electronic refuse] during disposal.

2 Safety

2.1 Warnings and Hazard Symbols

The following concepts or signs for especially important information are used in these Operating Instructions:



WARNING! **Risk of personal injury!**
You must observe this warning to avoid hazardous situations!



CAUTION! **Risk of material damages!**
There is no warranty claim in the case of damages!
You must observe this warning to avoid damages!

Note: Special information with regard to performing operating, maintenance and repair procedures, such as tips on performing an action efficiently.

2.2 Basic Safety Regulations

The device has been manufactured according to state-of-the-art technology and current safety regulations.

Nevertheless, the device can cause specific risks if it is installed by persons with insufficient training or if it is used incorrectly or not for its intended purpose.

Observe the following accident prevention regulations:

- The company's accident prevention regulations**
- Accident prevention regulations
- VDE safety regulations

2.3 Spare Parts, Accessories

Section "Spare Parts, Accessories", page 26, contains a list of the original spare parts.

We strongly advise you against installing accessories and spare parts that have not been authorized by **Kelch & Links GmbH**. **Kelch & Links GmbH** has not tested and approved such parts, and their installation may change the device's intended properties. This may affect the active and passive safety of the device!

Damages incurred through the use of non-original spare parts and accessories excludes all liability and warranty on the part of **Kelch & Links GmbH**.

2.4 Requirements for Operating and Maintenance Personnel

Each person who is involved in setting up, installing, initially operating, operating and maintaining the device must have read and understood these Operating Instructions and the sections "Safety" and "Operation" in particular before coming into contact with the device. This applies especially to persons who will only work occasionally at the device.

The operator is obliged to instruct operating and maintenance personnel in operating and maintaining the device, taking all safety regulations into account.

The device may only be operated and maintained by those persons who have participated in relevant training. This applies particularly to work at the device's electrical, pneumatic or mechanical equipment.

Personnel who are to be trained, educated or instructed, or personnel attending general training may only use this device only under the permanent supervision of an experienced person!

If several people are working at the device, the responsibilities for the individual tasks must be clearly defined and adhered to. There must be no unclear competencies with regard to safety!

Note: Inform operating personnel before special and maintenance work begins. Supervisors must be named!

2.5 Protective Clothing

To avoid accidents, the **company's clothing regulations must be observed!**

The operating personnel are obliged to wear the following protective clothing when working with tools:



Boots

Risk of injury!

A dropped part may result in injuries to feet. Therefore, always wear steel toe-capped boots!



Gloves

Risk of injury!

Sharp edges or metal chips that are stuck to the tool may cause cuts and lacerations.
Therefore, always wear protective gloves!

2.6 Safety Stickers on the Device

Ensure that all safety and hazard warnings on the device are legible and observe them!

2.7 Danger Zones at the Device

Risks during operation:

Danger Zone	Risk	Safety Instructions
Tool	Cuts	Wear gloves.
Height adjustment	Crushing	Hold the unlocked height adjustment securely.
Power strip	Electric shock	Do not insert pointed metal objects into the sockets.
Lighting equipment (projector version only)	Burns	The projector's halogen bulb becomes hot during operation. When exchanging the halogen bulb, allow it to cool down and always wear clean protective gloves!

2.8 Dangers of Electrical Energy

The tool adjusting device must not be operated if the casing is open.

The device must not be operated in environments that are prone to explosions.

The device must not be exposed to condensation or liquids.

If loose cable connections, incorrect insulation, burned cables or other defects are detected that affect the electrical safety of the tool adjusting device, the tool adjusting device must be switched off immediately and should not be operated again until the defect has been eliminated.

The electrical connection of the tool adjusting device to the power supply and work on the electrical equipment has to be performed by qualified personnel, taking into account the relevant VDE regulations or the regulations and provisions that apply at the installation site.

2.9 Compressed Air Supply

Work on the compressed air system should only be carried out by qualified staff, taking into account the regulations and provisions that apply at the installation site.

Kelch & Links GmbH shall not accept any liability if these regulations and provisions are contravened.

Pressure hoses and cables and screw fastenings must be checked regularly to ensure they are intact and must be replaced immediately even if they are only slightly damaged.

2.10 Opening the Casing

The tool adjusting device's casing should only be opened by qualified **Kelch & Links GmbH** staff!

Kelch & Links GmbH shall not accept any liability if this is contravened.

3 Operation

3.1 Components



Fig. 3-1: SECA operating and display elements (without control device)

The adjusting device has separate axes for X (radius of the tool to be measured) and Z (length of the tool to be measured).

Fine adjustment of the X and Z axis is via the hand wheels (3) and (6). The individual axes can be adjusted quickly using buttons on the handle (2) provided the device's pneumatics is supplied with compressed air via the pressure reducer (5).

Quick adjustment

To move an axis quickly, proceed as follows:

- ☞ Hold the handle (2) firmly. The weight of the measuring carriage is compensated by a counterweight for SECA. As a result, you do not require a lot of strength to maintain the height when the brakes are released.
- ☞ Unlock the X axis (–) and, if necessary, the Z axis (|) by pressing the buttons on the handle (2).
- ☞ Move the measuring carriage to the required position. This is generally the position in which the edge of the tool can be seen on the display device's screen.
- ☞ Release the button(s) and then the handle.
 - ⇒ *When you release the buttons, the axes are immediately locked. You can use the hand wheels to finely adjust the axes throughout the adjustment area.*

3.2 SECA Variants

Variant	Measurement	Detector	Measurement Control
SECA C MICRO	Ball-type nipple for receiving sleeves SK50 / SK40 / SK30 / HSK63	Projector	MICRO measuring electronics
SECA C EASY	Ball-type nipple for receiving sleeves SK50 / SK40 / SK30 / HSK63	Projector	PC (EASY eco) with 15" TFT
SECA C Micro Vision	Ball-type nipple for receiving sleeves SK50 / SK40 / SK30 / HSK63	Camera	MicroVision measuring electronics with 10" TFT
SECA C EASY Vision	Ball-type nipple for receiving sleeves SK50 / SK40 / SK30 / HSK63	Camera	PC (EASY Vision) with 15" TFT
SECA E MICRO	Spindle SK50 vacuum	Projector	MICRO measuring electronics
SECA E EASY	Spindle SK50 vacuum	Projector	PC (EASY eco) with 15" TFT
SECA E Micro Vision	Spindle SK50 vacuum	Camera	MicroVision measuring electronics with 10" TFT
SECA E EASY Vision	Spindle SK50 vacuum	Camera	PC (EASY Vision) with 15" TFT

3.3 Measuring Carriage

SECA is delivered with a projector or a camera. It can be upgraded within a few minutes by the **Kelch & Links GmbH** service team. The measuring carriage is positioned during the measuring process in such a way that the tool edge to be measured is between the light and the measuring optical instrument.

Operation of the control device is described in separate operating instructions.

3.3.1 Projector

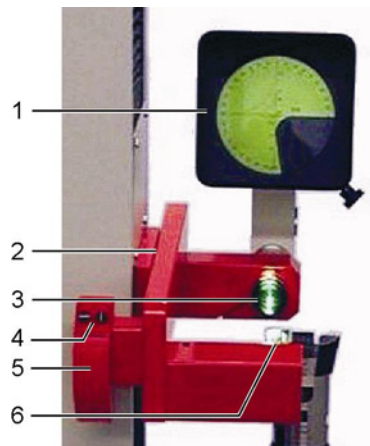

- | | |
|-----------------------------|------------------------------------|
| 1 Projector with crosshairs | 4 Unlocking buttons X, Z |
| 2 Measuring carriage | 5 Handle for quick adjustment X, Z |
| 3 Projector optical element | 6 Projector light |

The projector's measuring position is controlled by the projector screen. The control device is used to display the measurement data and to manage the adapter data.

Note: Observe the operating instructions for the control device!

3.3.2 Camera

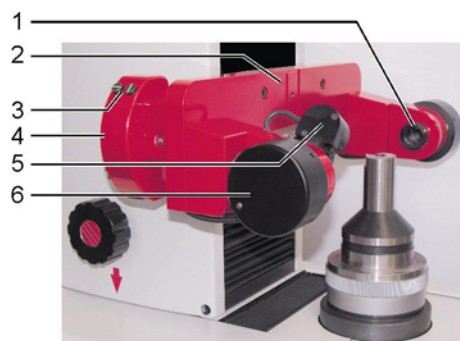

- | | |
|--------------------------|------------------------------------|
| 1 LED transmitted light | 4 Handle for quick adjustment X, Z |
| 2 Measuring carriage | 5 LED incident light (optional) |
| 3 Unlocking buttons X, Z | 6 CMOS camera |

The camera's measuring position is controlled using the screen at the control device (MICRO or EASY). When you select a measuring program, you only need to position the edge to be measured in the display area, since the edges can be determined automatically by the image processing software.

Note: Observe the operating instructions for the control device!

3.4 Preparation for Measurement

☞ Remove the X axis from the tool's area so that the work area is free.



Fig. 3-2: Inserting the receiving sleeve (accessories) into the ball-type nipple (SECA C only)

☞ Make sure you use a receiving sleeve that is suitable for the tool and that you have selected the correct adapter for the control device (see "Saving the Adapter", page 15). In the spindle or the receiving sleeve you can use various types of adapters, from simple reductions to adapters for non-rotating tools of type VDI.

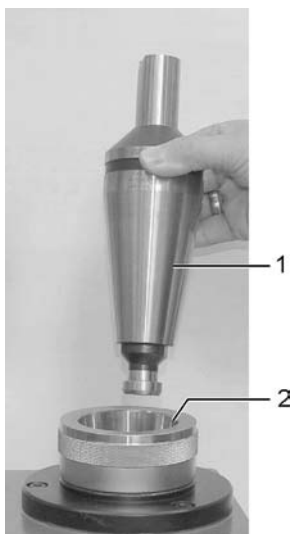

1 Tool 2 Adapter

Fig. 3-3: Inserting the tool (in this example, a setting mandrel)



CAUTION! Possible damage to the setting drives!

Metal chips, sand and other soiling can damage the setting drives for the X and Z axis.

Note: Ensure that you keep the contact areas between the tool (1) and the receiving sleeve (2) absolutely clean!

The slightest soiling will render the measurement result unusable!

Note: To avoid incorrect measurements, the tool should be at ambient temperature.

☞ Insert the tool into the top of the receiving sleeve. In doing so, ensure that no metal chips or other soiling enters the adjusting device.

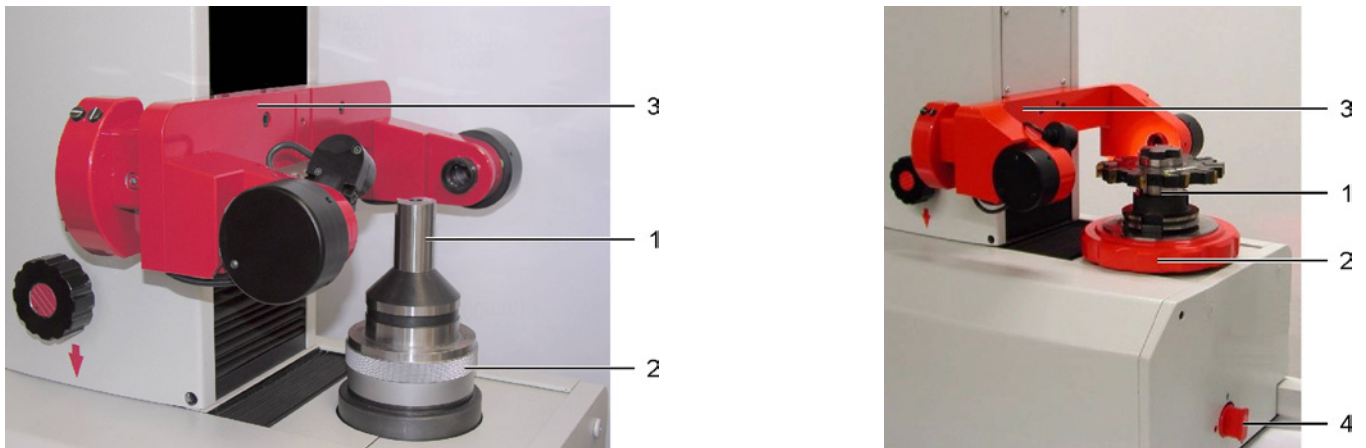

1 Tool 2 Adapter/receiving sleeve 3 Measurement carriage 4 Rotary switch for headstock (SECA E)

Fig. 3-4: Positioning the tool (SECA C left, SECA E right)

- ☞ SECA E has a rotary switch for locking or braking the headstock, and thus the adapter, with the following settings:
- "Red": Spindle is braked.
 - "Green": Spindle can rotate freely.
 - "Yellow": Spindle locks at 90° (90° indexing). The spindle is released by turning the selector switch to the green mark.
 - "Vacuum": To switch on the tool's vacuum voltage, pull the selector switch out. Push the selector switch back to its original position to switch off the vacuum voltage.



CAUTION! Possible damage to the headstock!
Only turn the locked adapter when it is set to "green"!

- ☞ Set the rotary switch to "green" (SECA E only).
- ☞ Rotate the tool to the measuring position (with SECA C, the tool can still be rotated in the ball-type nipple). Turn the edge so it is positioned in the area in focus (towards X).
- ☞ Fasten the adapter using the rotary switch (SECA E only).
- ☞ Ensure that the main switch is on (power strip on the reverse of the device)
- ⇒ *You can now measure the tool.*

3.5 Measuring Radius (X) and Length (Z)

3.5.1 Projector Version

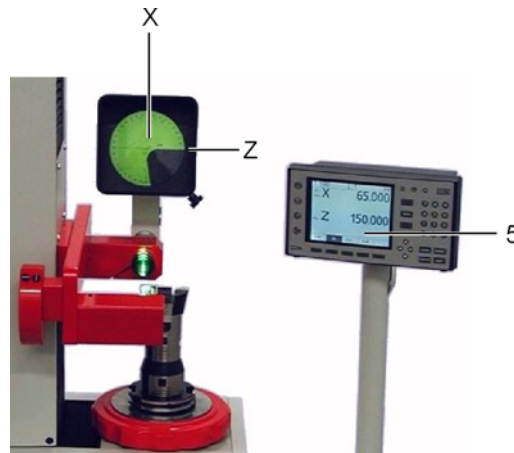

- ☞ Move the measuring carriage until the cutting edge appears in the projector.
- ☞ Bring the edge that is displayed in the projector into focus (turn the spindle, highest point of the edge!)
- ☞ Finely adjust the Z axis setting so that the top edge (Z) of the tool touches the X axis of the crosshair displayed in the projector from the bottom, but does not cut across it.
- ☞ Finely adjust the X axis so that the left edge (X) of the tool touches the Z axis of the crosshair displayed in the projector from the right, but does not cut across it.
- ☞ Read the values of X and Z on the screen display (5).

Note: Observe the operating instructions for the control device!

Troubleshooting in the projector

Fault	Cause	Correction
Image appears cloudy	The viewing screen or front lens on the lens/camera is soiled (dust, oil, coolant, fingerprints, etc.).	Absorb oil and other liquids using soft blotting paper. Clean with glass cleaner.
Image appears dark, but in focus	The light is dirty.	Clean the light, making sure you do not leave any fingerprints behind. Traces of grease can burn into the glass! Clean with alcohol.
	The light tube has misted over due to vapour caused by the filament.	Change the bulb. If the problem re-occurs after a short time, measure the voltage.
Image is not illuminated	The bulb is defective.	Change the bulb.
	Power supply is defective.	If the problem re-occurs after a short time, measure the voltage under load.

3.5.2 Camera Version

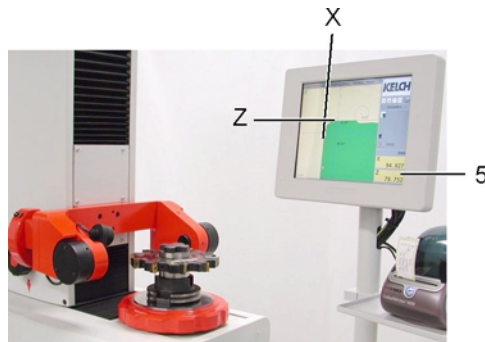

- ☞ Move the measuring carriage until the cutting edge appears in the projector.
- ☞ Determine the coordinates according to the operating instructions for measurement control (MICRO Vision or EASY Vision), then read the values of X and Z on the screen display (5).

Note: Observe the operating instructions for the control device!

3.6 Completing the Measurement

- ☞ Remove the measuring carriage from the work area.
- ☞ Release the tool (SECA E: switch off the vacuum by pressing the rotary switch).
- ☞ Remove the tool from the adapter.
- ☞ Switch off the main switch once you have finished measuring!

3.7 Saving the Adapter

Calibrate the display instruments (= save the adapter) for the X and Z axis using the known measured variables of a setting mandrel.

- ☞ Measure the radius (X) and length (Z) of the setting mandrel (see "Measuring Radius (X) and Length (Z)", page 14).
- ☞ Save the values according to the operating instructions for the control device in a suitable adapter data record. This adapter applies to all measurements using the current tool holder.

Note: Observe the operating instructions for the control device!

3.8 Technical Data

Designation		Data (SECA C)	Data (SECA E)
Measuring area	Z axis	0 – 400 mm	0 – 500 mm
	X axis	0 – 330 mm	0 – 330 mm
Receiving sleeve		SK30, SK40, SK50, HSK63 (see "Spare Parts, Accessories", page 26)	SK50 vacuum
Edge scanning		See "SECA Variants" page 10)	
Measurement control		See "SECA Variants", page 10)	
Ambient temperature		0 – 40°C	
Relative humidity		≤ 80 %	
Space requirement	W x D x H	1,080 mm x 660 mm x 980 m m	1,080 mm x 660 mm x 1,080 m m
Weight		155 kg	175 kg

4 Initial Operation

4.1 Transport/Packaging/Storage

The device is dispatched in stable crates. The heavy weight means there is a risk of injuries if the crate falls.



WARNING! Risk of injury!

A falling crate can cause personal injury! Ensure that the crate is generally secure during all stages of its transportation!

Take care during unloading! Avoid dropping or knocking the machine components!

Make sure that the permissible crane load is sufficient. Chains, ropes, hooks and lifting eyes must be free of technical defects and similarly be sufficient for the specified weights.

Weight information can be found in the technical data table in these instructions. If suitable lifting equipment is not available, an appropriate transportation company must be commissioned to unload the device.

Always lift up machine components smoothly!

Always stand well clear of suspended loads; danger of death!

Transport safety devices must be assembled for transport.

If the machine was delivered in transport containers (overseas crates), all the information required for unloading (load fastening point, crane load) must be printed on the container.

If the device is wrapped in foil, this must not be damaged if the device is stored! Otherwise, this will void any liability on the part of **Kelch & Links GmbH!**

4.2 Scope of Delivery

When the delivery arrives at the point of destination, it must be checked immediately for completeness using the shipping documents and packing lists. The transportation company is liable for any damage incurred during transport!

Below is the packing list for the Tool Adjusting Device:

Item	Designation	Number	Comment
1	SECA	1	Tool Adjusting Device completely assembled
2	Control device	1	MICRO, Micro Vision, or PC with USB junction box
3	Adapter light supply	1	Adapter for 3-pin plug adapter for the light supply
4	Operating Instructions	1	This document
5	Operating instructions for the control device	1	Essential for optimum use of the device functions
6	Packing list	1	
7	CE declaration of conformity	1	
8	Printer (optional)		Label printing

4.3 Transport Safety Devices

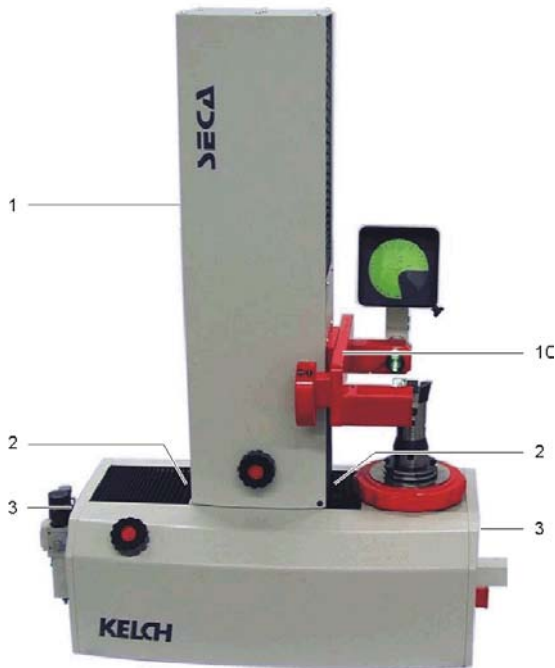

- 1 Two transport safety screws
- 2 Axle transport safety devices
- 3 Threaded holes
- 10 Measuring carriage

Note: Always use the threaded holes (3) when transporting with lifting gear. Lifting ropes must not touch the vertical tower!

☞ Remove the axle transport safety devices (2).

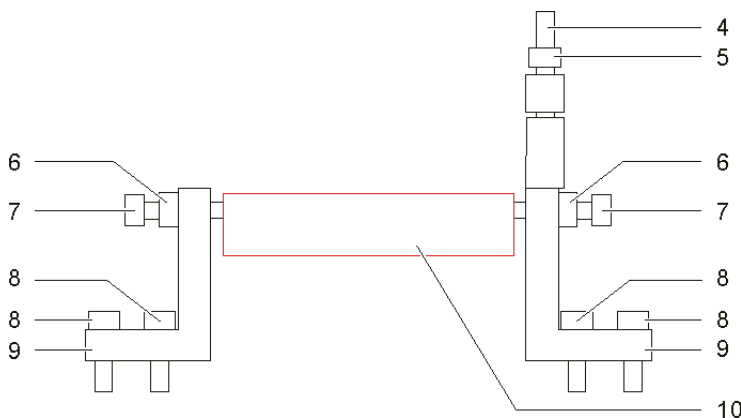

- 4 Threaded rod
- 5 Counternut
- 6 Counternuts (2x)
- 7 Bolts (2x)
- 8 Bolts (4x)
- 9 Holders (2x)
- 10 Measuring carriage

☞ Remove the counternut (5) and unscrew the threaded rod (4).

☞ Loosen the two counternuts (6) and bolts (7).

☞ Loosen the four bolts (8) and remove the two holders (9).

⇒ *The measuring carriage transport safety device has now been removed.*

☞ Move the optical instrument holder (Z axis) downwards until it is no longer possible to move the fine adjustment Z downwards.

⇒ *Rope for the counterweight is subject to a load, the counterweight cannot suddenly fall down.*

☞ Remove the transport safety screws (1) from behind the plastic cover.

☞ If necessary, re-attach the axle covers on both sides using self-gripping fasteners.

4.4 Cleaning

The machine components are supplied with corrosion protection.

☞ Use a **cold cleaning agent** to clean the machine components.



CAUTION! Risk of damage to device through degreasing!

When cleaning the machine components and removing the corrosion protection, do not use chlorinated hydrocarbons such as PER, TRI, etc.

Never use steam jets, compressed water or compressed air for cleaning! These can cause dirt or cleaning agents to enter the guides and seals, disabling functions, especially safety functions, limit switches or measurement systems.



WARNING! Fire hazard!

If you use petroleum ether, you should only carry out cleaning in the open air, taking special safety precautions (fire hazard).

☞ Collect the runoff of cleaning agents and dispose of it properly.

4.5 Assembly

The unit is delivered fully assembled. Horizontal adjustment is not required. The unit can be adjusted using the 3 adjusting screws located in the foot.

☞ Use the adjusting screws and a spirit level on the adapter's flat surface to ensure that the body is horizontal in both directions (swivel the spirit level horizontally by 90).

4.6 Pneumatic Connection

- ☞ Attach the pneumatic connection to the compressed air supply (4-6 bar pre-cleaned, hose connection LC 6 with hose clamp).
- ☞ Set the operating pressure to min. 4 bar.

Note: The maintenance unit with a filter and pressure regulator valve is included in the delivery. Do not add oil!

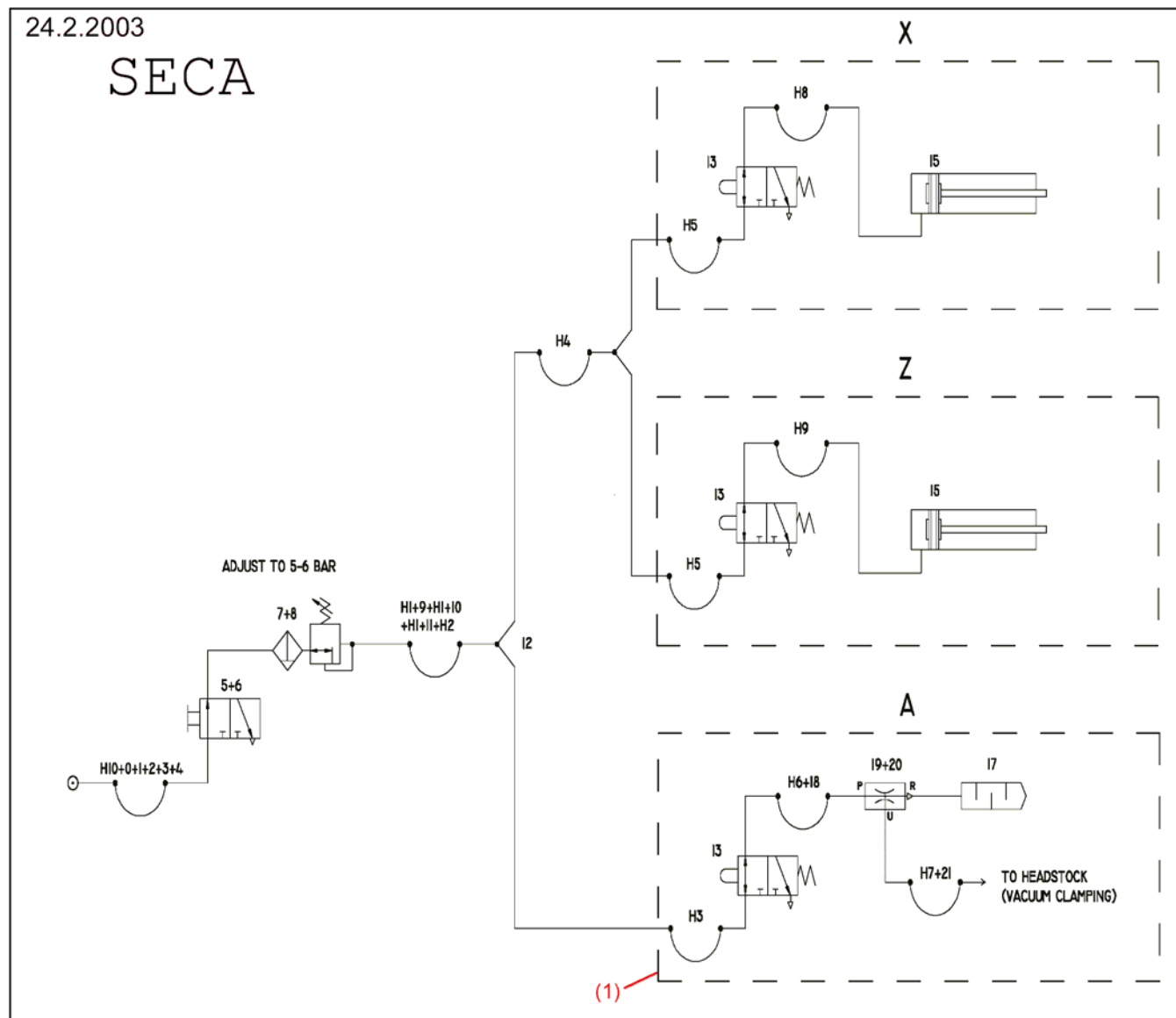

Fig. 4-1: Pneumatic diagram, vacuum (1) for headstock only SECA E

4.7 Electrical Connection

The device is connected to the workshop's power supply via a country-specific (Euro/USA) plug.

Additional devices (monitor, control device) are supplied by a power strip with a main switch that is screwed onto the back of the device.

Note: The main switch on the power strip switches off the electricity for the whole device.

Connection Values

Power connection 90 – 260 V, 47-63 Hz, 16 A, connection value approx. 105 W with compact controller (KELCH Micro) and printer, up to approx. 300 W with PC.

4.7.1 Cable for Connecting the Control Device

The control device is not cabled upon delivery, even though the cables have already been guided by the support arm for the control device.

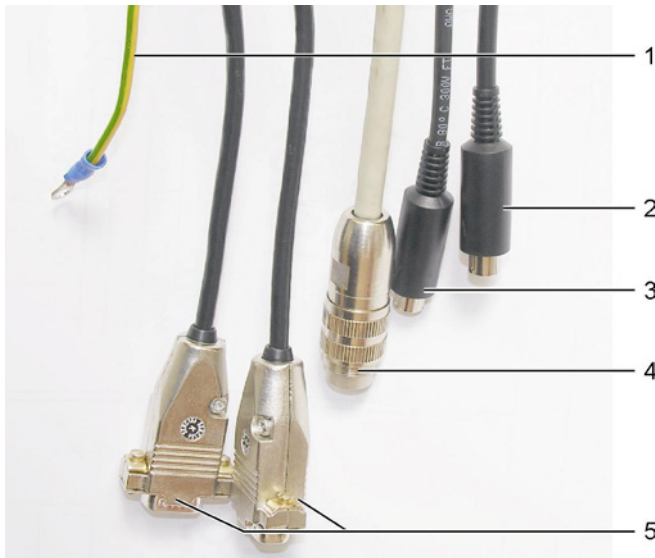

- 1 Casing earthing (ground contact)
- 2 Camera image data (8-pin)
- 3 Incident light supply 5 V (3-pin)
- 4 Transmitted light supply 12 V (3-pin using adapter)
- 5 X axis (1), Z axis (2), 9-pin

4.7.2 MICRO



- 1 Fine-wire fuse F1,6 A T
- 2 Main switch
- 3 Power supply
- 4 Parallel printer connection
- 5 Transmitted light supply (using adapter)
- 6 Axis data X (input 1), Z axis data (input 2)
- 7 RS-232 serial printer
- 8 RS-232 service plug

Note: For the MICRO control device, the cables for image data and incident light are **not** connected.

4.7.3 Micro Vision



- 1 5 V incident light (3-pin) supply
- 2 PS2 mouse
- 3 Camera (8-pin)
- 4 X axis (top), Z axis (bottom)
- 5 Printer (USB)
- 6 Transmitted light supply (12 V using adapter)
- 7 Ground contact

Note: For the MicroVision control unit, the connections are labelled by pictograms on the back of the casing.

4.7.4 EASY, EASY Vision

The cable is connected to the PC using an interface box. The connections are labelled.

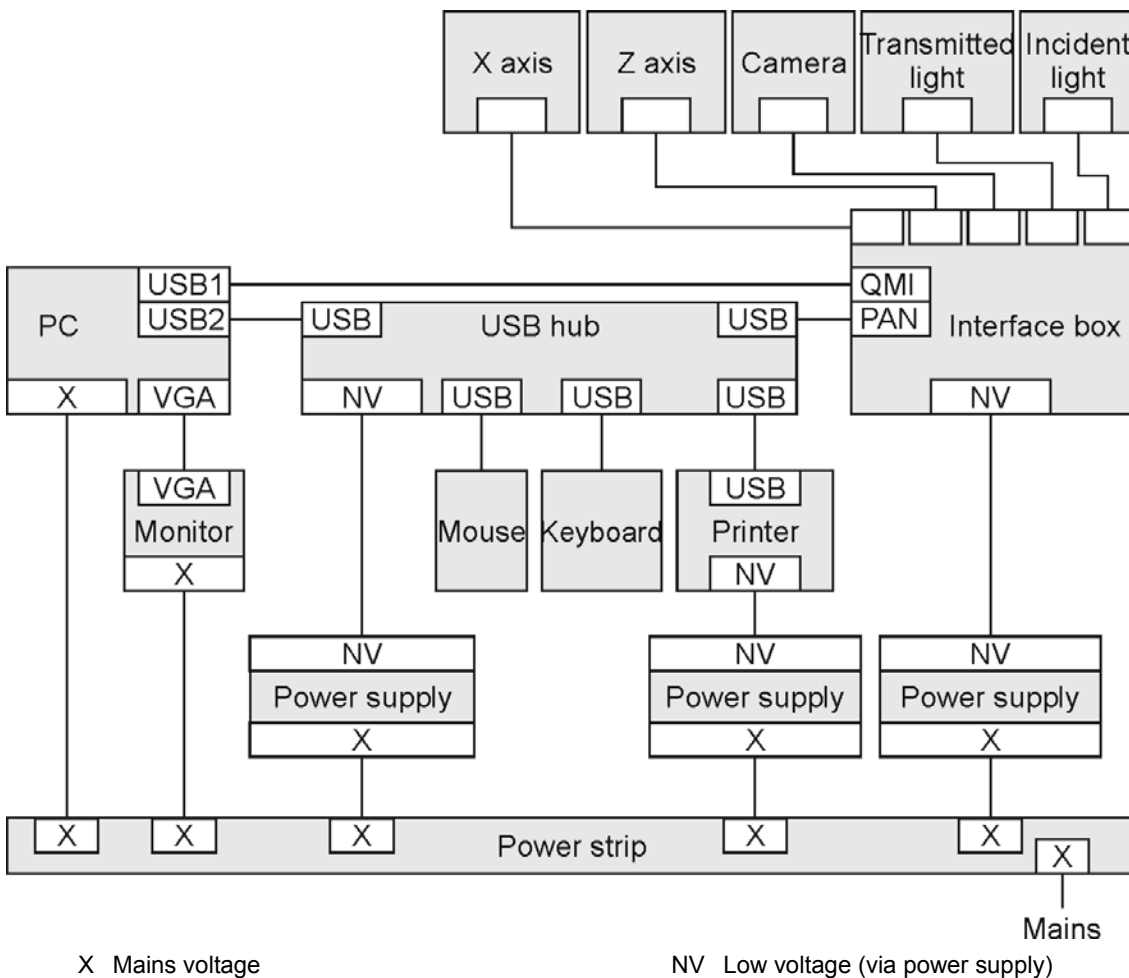

4.7.5 Procedure for Cabling

- ☞ Ensure that the power strip is not connected to the power supply.
- ☞ Connect all the power cables from the monitor, printer power supply unit and PC to the power strip. The devices are then switched on together using the switch on the power strip.
- ☞ Switch on the power switch on the back of the PC.
- ☞ Connect the SECA cable according to the label to the interface box (EASY) or the control device.
- ☞ Insert the printer cable into the printer (for labels) and into the USB hub (EASY) or the control device.
- ☞ Insert the low-voltage cable of the printer power supply unit into the back of the printer on the right.
- ☞ Set the switch on the right-hand side of the printer to "I" (On).
- ☞ Insert the label roll into the printer. (The instructions for inserting the roll are attached to the inside of the printer.)
- ☞ EASY: Insert the mouse and keyboard into the USB hub. MicroVision: Insert the mouse into the control device.
- ☞ EASY only: Connect the USB hub power supply unit to the USB hub (low-voltage cable) and the power strip (power cable).
- ☞ EASY only: Connect the interface box power supply unit to the interface box (low-voltage cable) and the power strip (power cable).
- ☞ Set the switch on the power strip to 0 (Off).
- ☞ Connect the power cable to the power supply.

5 Maintenance and Service

5.1 Cleaning

You can ensure the functioning of the device by cleaning it regularly with a soft, lint-free cloth and oiling it with a preservative such as silicon oil.

If the unit is visibly soiled, you can also clean it using a commercially available cold cleaning agent.

Follow the cleaning notes (see Cleaning, page 19)!

5.2 Maintenance

All mountings on rolling bearings are permanently lubricated.

Any grease nipples that exist are standard elements at the corresponding components. The low load means that the bearings do not require lubrication.

Ensure that the live parts of the device are kept free of metal chips. Do not use compressed air to clean the device!

To be able to work permanently with the expected accuracy requirements as well as outstanding quality, we recommend that you have maintenance work carried out by qualified Kelch staff.

You can copy the following maintenance plan and use it as a checklist. Once the work has been completed, sign and date the completed page and archive it as a log.

Maintenance Work	MAINTENANCE INTERVAL						Result	
	Daily	Week-ly	Month-ly	Biann-ually	Ann-ually	Every 2 years	Works	Def-ective
Check protective covers.	X						<input type="checkbox"/>	<input type="checkbox"/>
Check guide protective covers for damage.	X						<input type="checkbox"/>	<input type="checkbox"/>
Check the maintenance unit setting (5 bar).	X						<input type="checkbox"/>	<input type="checkbox"/>
Check the air pipes and valves for leaks.		X					<input type="checkbox"/>	<input type="checkbox"/>
Clean or exchange air filters (PC).			X				<input type="checkbox"/>	<input type="checkbox"/>
Check ropes, idler rollers and axes of the counterbalance for damaged components. Exchange damaged components.					X		<input type="checkbox"/>	<input type="checkbox"/>
Check concentricity of tool holder.					X		<input type="checkbox"/>	<input type="checkbox"/>
Check the parallelism of the taper chuck for longitudinal guidance.					X		<input type="checkbox"/>	<input type="checkbox"/>
Check the focus adjustment of the projector/camera.					X		<input type="checkbox"/>	<input type="checkbox"/>
Check the light source setting and adjust it if necessary.					X		<input type="checkbox"/>	<input type="checkbox"/>
Check the shaft and idler rollers for wear, and replace parts if worn.						X	<input type="checkbox"/>	<input type="checkbox"/>
<p>Lack of or improper maintenance of the equipment can lead to:</p> <ul style="list-style-type: none"> - Inadequate operating safety - Unnecessary downtimes - Avoidable repair costs - Reduced service life 		<p>We recommend maintenance by:</p> <p>Qualified Kelch staff Tel + 49 (0)7181 / 925 -212 -213 -282 Fax + 49 (0)7181 / 925 220</p> <p>Date: Signature:</p>						

5.3 Spare Parts, Accessories

Order Number	Assignment	Designation
041 4796	SECA C	SK 50 sleeve (accessories)
041 4871	SECA C	SK 40 sleeve (accessories)
041 4901	SECA C	SK 30 sleeve (accessories)
103 1344	SECA C	HSK 63 sleeve (accessories)
103 9610	SECA C, E: Projector device	Projector 110 mm
104 3782	SECA C, E: Projector device	Holder for projector
103 9657	SECA C, E: Camera device	Lighting unit
	SECA C, E: Camera device	CCD camera
	SECA C, E: Camera device	LED transmitted light
	SECA C, E: Camera device	LED incident light
104 3778	SECA C, E: Camera device	Holder for camera
104 5539	SECA C, E	Covers X (2 x 240 mm)
104 5540	SECA C	Covers Z (4 x 540 mm)
104 5541	SECA E	Covers Z
104 4051	SECA C: Projector device	SK 50 setting mandrel
104 4052	SECA C: Projector device	SK 40 setting mandrel
104 4053	SECA C: Projector device	SK 30 setting mandrel
104 4054	SECA C: Projector device	HSK 63 setting mandrel
104 4058	SECA C: Camera device	SK 50 setting mandrel
104 4057	SECA C: Camera device	SK 40 setting mandrel
104 4056	SECA C: Camera device	SK 30 setting mandrel
104 4055	SECA C: Camera device	HSK 63 setting mandrel
	SECA C, E: Micro	MICRO control device
	SECA C, E: Micro Vision	Microvision control device
	SECA C, E: EASY	EASY (PC) control device
	SECA C, E: EASY	USB adapter box
104 3194	SECA C, E	Device cabinet, Hoffmann W x D x H = 1,500 mm x 700 mm x 850 mm